



Spinder rope scraper

Assembly manual Spinder rope scraper

Dear user,

These are the mounting instructions for the Spinder Livestock Housing rope drive model scraper installation. These mounting instructions are to help you install the equipment in the correct manner. For that reason we suggest you carefully read and keep this manual. We reserve the right to change the text, drawings, graphs, etc. without prior notification.

PLEASE NOTE:

Due to technological changes, the illustrations and graphs shown in this manual may slightly differ from your system!



All fields containing functions, elements or parts marked with an asterisk (*) are either optional or accessories, and are therefore not standard part of the system. Descriptions and instructions for improvements, extra components and functions are shown in the appendix to this manual.

Carefully read these user instructions before you put the installation into use. Keep this manual in a safe place for future reference!

Parts and customer service:

For contact::

© Spinder Dairy Housing Concepts
Zeppelinlaan 3
9207 JG Drachten
The Netherlands

☎ 00 31 (0)512 - 237800

E-mail: info@spinder.nl
Website: www.spinderdhc.com

Inhoudsopgave

1 Information about these mounting instructions	3
2 Safety	4
2.1 Conscious use	4
2.2 Automatically putting into operation	4
2.3 What to do in the event of imminent danger	4
2.4 Hazard: Electric shock	5
2.5 Hazard: moving scraper	5
2.6 Hazard: the moving rope	5
2.7 Hazard: fire	6
2.8 Protective covers	6
2.9 Residual risks	6
3 Parts	7
3.1 Parts of the installation	7
3.2 Types of manure scrapers	10
3.2.1 Slat scraper	10
3.2.2 Combi scraper straight model	10
3.2.3 Combi scraper V-shape model	10
4 Assembly	16
4.1 Assembly of the drive units on the floor	16
4.1.1 Assembly protective cover drive units on the floor	16
4.2 Mounting the drive unit to the console	18
4.2.1 Assembly protective cover drive units on console	18
4.3 Mounting corner wheels	21
4.3.1 Assembling the corner wheel protective cover	21
4.4 Assembly stop	24
4.5 Assembling the discharge	25
4.6 Installing the control box	34
4.6.1 COMFORT control box	34
4.6.2 Extension module (EXP 200)	39
4.6.3 BASIC control box	41
4.6.4 Cable types, lengths and diameters	43
4.7 Assembly of safety elements	45
4.8 Motor test (testing the direction of rotation of the motor)	46
4.9 Attaching the rope	47
4.9.1 Attaching the rope to the installation	47
4.9.2 Attaching the rope to the drive unit	50
4.9.3 Attaching the rope to the scraper	51
4.10 Adjusting the brake band	53
5 Maintenance	54
5.1 Drive unit	54
5.2 Corner pulleys	54
5.3 Manure scraper	54
5.4 Maintenance summary	55
5.5 Gearbox – type of oil and quantity	55
6 Technical data	56
EC declaration of conformity	58

1 Information about these mounting instructions

These mounting instructions describe the steps required for the assembly and maintenance of your scraper installation. The documentation is based on situations you may encounter at work daily.

These mounting instructions must be read and understood by all those who work with the installation. Here you will find important information about working with the installation.

1.1 Definitions / description / concepts

Installation An installation consists of two single or one double drive unit and can carry one or two manure scrapers.

Track A track may have one or two channels. A drive is required for each track.

1.2 Symbols used

- This gives you a list.
- This gives you a breakdown of the main parts.
- >>> This gives you the result of an action.

1.3 Copyright

Spinder B.V. Harkema holds the copyrights of this edition. Copying, in full or in part, is permitted only with written consent and quoting the source 'Mounting instructions Spinder rope installation'. Infringements of copyright may be taken to Court.

1.4 Appropriate use

Reliability is guaranteed only in the event of appropriate use of the installation.

The installation described in these operating instructions is appropriately used only as a means to remove manure from closed and slatted floors in barns.

Please also pay attention to the values shown in chapter 'Technical data' and the safety and user instructions as described in this manual.



PLEASE NOTE!:

Failing to meet the above-mentioned points may compromise the reliability of the installation. The manufacturer assumes no liability for personal injuries and/or material damage of any kind as a result of inappropriate use of the installation. The manufacturer will not allow any unauthorised technical changes to the installation or parts thereof. Actions in violation of those mentioned in these mounting instructions will void any form of warranty and the manufacturer will not be held responsible for the consequences.

2 Safety

The user will make sure that the assembly and maintenance of the installation will be carried out by authorised and certified persons.

2.1 Conscious use

All operators of the installation must be duly qualified.

Such persons know how the installation works, they know the safety instructions, they know any hazards that may loom, and they have read and understood these directions for use.

Safety guarantee:

- Prior to doing any maintenance work, the installation must be turned off and powered off.
- Make sure that all safety and protection gear has been tested and put into place before the installation is put into use.

Disallowed:

- maintenance to a running installation.
- independently changing parts of the installation.
- working methods that may compromise the safety of the installation.

2.2 Automatically putting into operation

The automatic start function (entering the starting times) allows the automatic start of the installation. The automatic start of the installation is subject to the following:

- No unauthorised persons (children in particular) are within the range of the installation.
- No harm can be done to the animals through structural obstacles.
- Safety devices, such as the main switch and the emergency stop, are within easy reach.
- No activities may take place in and around the installation in the form of servicing, maintenance, cleaning, etc.

Starting the installation is via:

- The auto function
- Manual start
- Manual start through external buttons of the control unit

2.3 What to do in the event of imminent danger

In the event of a fault or a problem:

- Turn the installation off using the emergency stop
- Turn the main switch off and make sure others cannot turn it back on.
- Eliminate the fault or the problem.



PLEASE NOTE!

Turn the main switch "OFF" before any repairs, maintenance or other activities within the working range of the installation. This will eliminate the risk of inadvertently starting the installation.

2.4 Hazard: Electric shock



PLEASE NOTE!!

All electrical work must be carried out by a certified electrician.

Test all safety equipment after completion of any work on the electrical installation.



PLEASE NOTE! – hazard: electric shock!

With the main switch powered on, the electrical wiring of the control box and the motor can be live. Before using an electric device, first turn the main switch off and then restart the installation.

Additional information:

- Do not work on electrical components that may be live.
- Treat cables and lines in such a way that no thermal, mechanical and electromagnetic load can occur.
- If all switches and components have been installed, connect the switches and components in the prescribed manner (installation control box / motor).
- Damaged or leaking electrical equipment (controller, buttons, motors, etc.) must be replaced without delay.
- Only the prescribed equipment must be used in the event of repairs to electrical parts.

2.5 Hazard: moving scraper

Keep the manure scraper at a safe distance from the fixed structures. Fixed structures include wall passages, posts and the manure dump; 500 mm would be considered a safe distance. Other safety measures must be taken in case there is insufficient room. For instance, installing a fence. Prevent the scraper from hooking behind corners, walls and the like. Bevel such corners and lower the parameter for deactivating the scraper for quick action if danger looms.

2.6 Hazard: the moving rope

Do not hold on to the rope under any circumstances. No unauthorised persons (children in particular) are allowed within the range of the installation when in operation.



PLEASE NOTE!

Regularly check the condition of the rope and replace it if damaged. Also check the scrapers and the drive unit for any wear.

2.7 Hazard: fire

Immediately turn the main switch in the event of a fire. Also disengage the system from the power mains (e.g. by removing the fuses). With the power turned on, the risks of electrical shocks and fire are many times greater than with the power turned off. Every control box contains high-quality electronics. Protect such electronics for damage. Use only residue-free CO2 fire extinguishers.

If such fire extinguishers are not available, use an extinguisher in the A, B or C category instead (these fire extinguishers cause much smoke damage).



PLEASE NOTE!

Incorrect use of fire extinguishers or other fire extinguishing equipment may create extra risks, e.g. highly dangerous electrical shocks or health-threatening vapours or gases.

2.8 Protective covers

Before the installation is put into operation, make sure that all safety components that came with the equipment are duly assembled.



PLEASE NOTE!

Protective covers and other safety components must be put in place before the installation is put into operation.

2.9 Residual risks

Measures have been taken to minimise the risks. However, some risks will remain, no matter which measures are put in place. Below is an enumeration of the greatest risks involved.

- Tripping over the driving rope; when you walk around, make sure the rope lies across the full length of the channel.
- If the drive units are mounted onto the floor outside, the driving rope is exposed between the corner wheel and the inlet of the protective cover. Watch out and do not trip over.
- When activated, the scraper installation will run automatically. Remember the manure scraper moves through the barn.
- A person's foot may get wedged between the openings in the stop of the scraper.

3 Parts

3.1 Parts of the installation

A complete installation consists of the following components:

1. Installation comprising two single drive units;
 - Made of galvanised or stainless steel.
 - Unit-driven electromotor with a reduction gear unit attached.
 - Galvanised protective covers.
 - Reel + spindle.
2. Drive units can be mounted onto the floor or onto a console
 - on a console, the drive unit can turn 360 degrees
3. Corner wheels, horizontally mounted;
 - Plastic corner wheels with steel bush bearings.
 - Casing in galvanised steel.
 - Protective cover.
4. Driving rope of 8 mm and 10mm PE rope, depending on the situation
5. Stop for the manure scraper (galvanised)
6. Control box, for controlling the drive unit, consisting of;
 - BASIC, for one drive line with standard programme
 - COMFORT, for up to 5 drive lines with various programmes
7. Main switch and emergency stop
8. Accessories;
 - External control
 - Drive barrier on scraper
 - Etc.
9. Manure scrapers are available in the following models;
 - Slat scraper
 - Combi scraper straight
 - Combi scraper V-shape

Examples of parts of the installation:



Corner wheel with protective cover



Combi scraper V-shape



Drive unit on floor

Scraper for grid floor

65.12.175 (grid floor)
65.12.170 (page)

65.12.165 (grid floor)
65.12.160 (page)

65.12.100

61.06.042 basis
61.06.044 comfort

65.12.150

65.84.116 (8mm)
65.84.125 (10mm)

Combi scraper

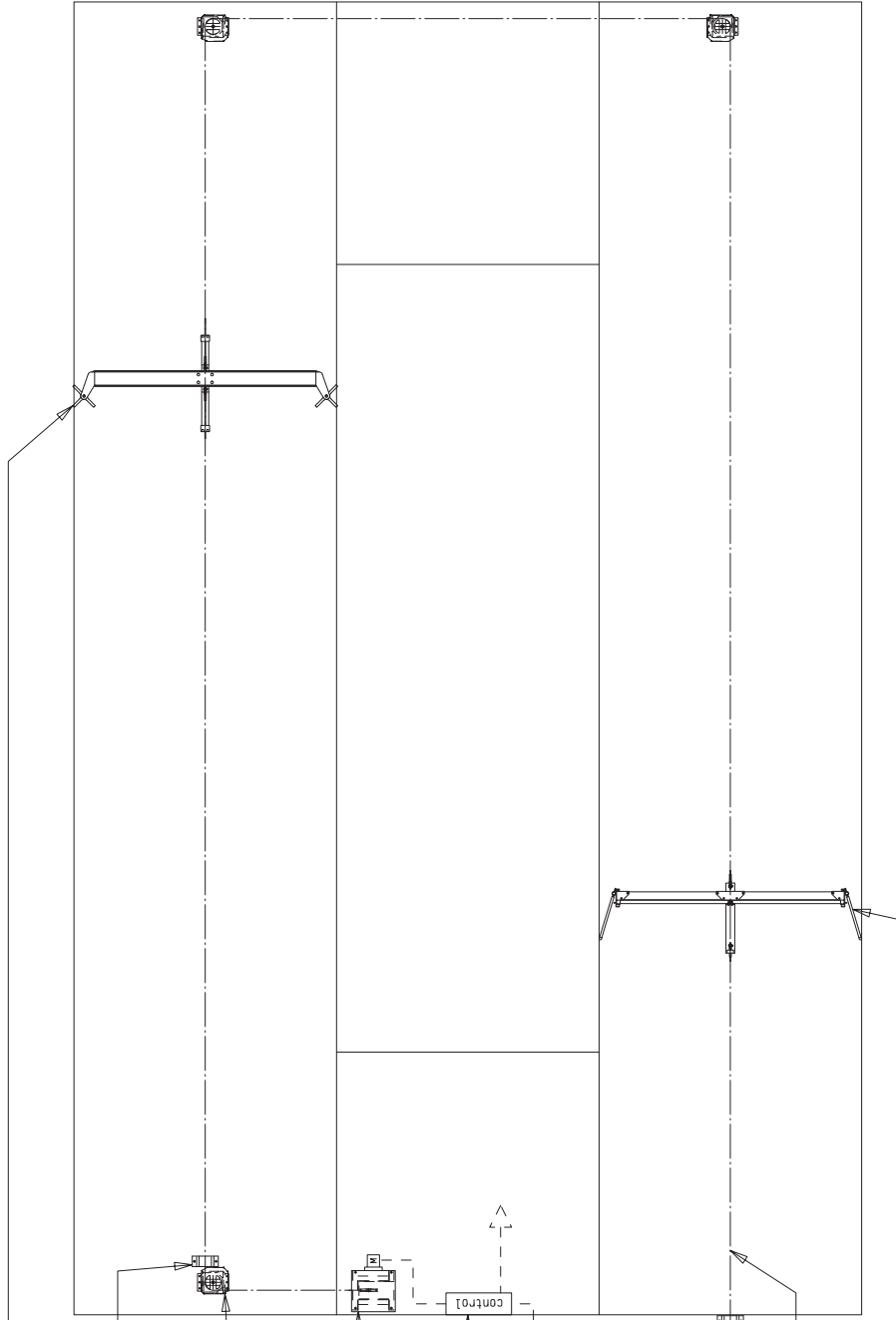

Component parts for rope system

Nr.:	170-010	Blad nr:	1:1
Schaal:	1:50	Maateenh:	mm
Ger.nr.:	0000		
Datum:	28-10-2014		
Get.:	P.d.J.	Gec:	

Mounting set:
for 65.12.100 / 65.12.150 on grid floor: 65.12.130
for 65.12.100 / 65.12.150 on concrete floor: 65.12.140

Tekening blijft ons eigendom en mag niet gereproduceerd, aan derden getoond of op andere wijze worden gebruikt.

Spinder
staimrichting
Harkema-Holland

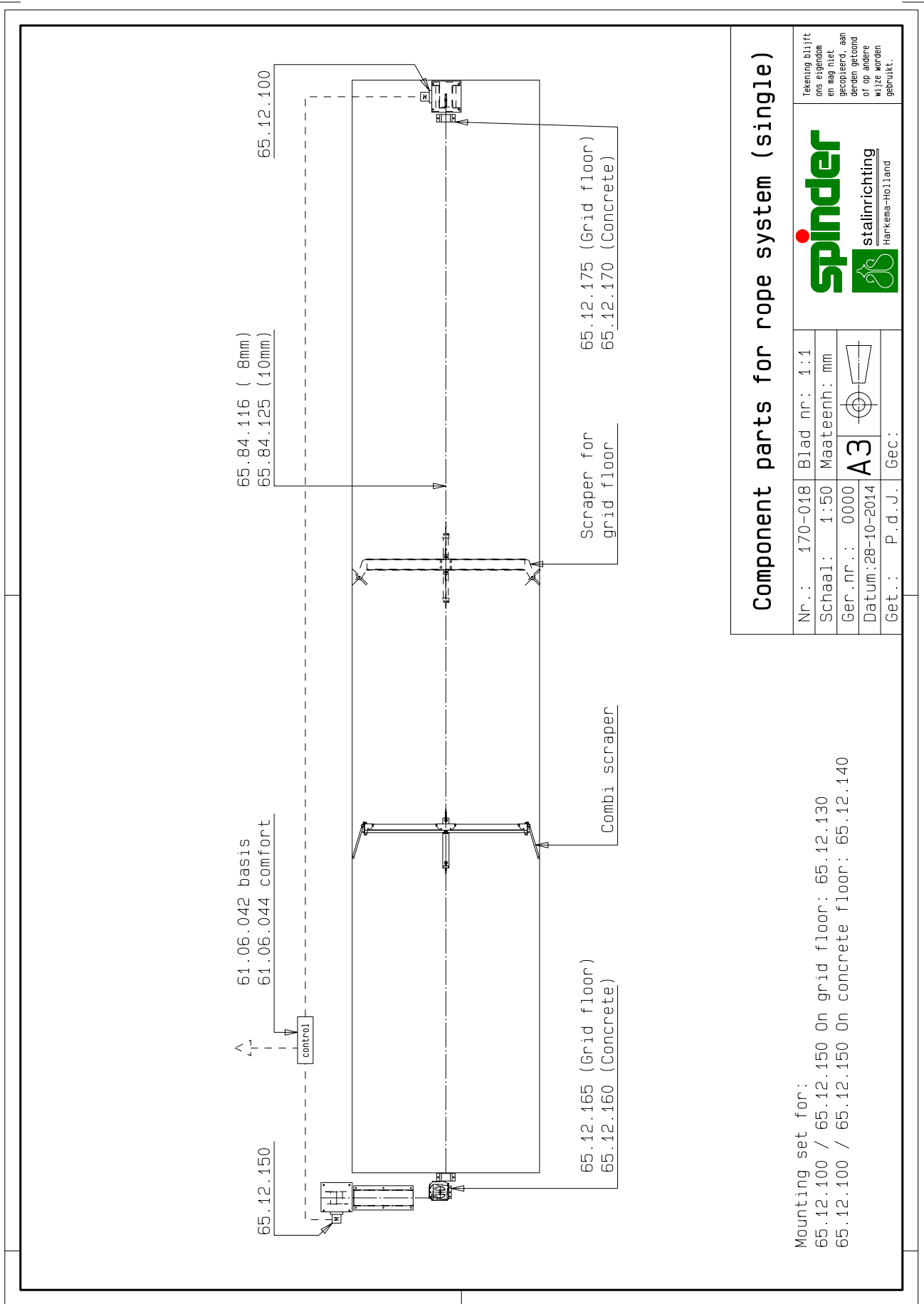

Component parts for rope system (single)

Mounting set for:
 65.12.100 / 65.12.150 On grid floor: 65.12.130
 65.12.100 / 65.12.150 On concrete floor: 65.12.140

Nr.:	170-018	Blad nr.:	1:1
Schaal:	1:50	Maateenh:	mm
Ger.nr.:	0000	A3	
Datum:	28-10-2014		
Get.:	P.d.J.	Get.:	

Tekening blijft ons eigendom en mag niet gereproduceerd, aangezien of op andere wijze worden gebruikt.

Spinder
 stalinrichting
 Harkema-Holland

3.2 Types of manure scrapers

Spinder supplies three types of manure scrapers:

- Slat scraper
- Combi scraper straight
- Combi scraper V-shape

All manure scrapers are available in the following sizes:

- 200 cm
- 201 cm - 250 cm
- 251 cm - 300 cm
- 301 cm - 350 cm
- 351 cm - 400 cm

3.2.1 Slat scraper

This manure scraper has a double rubber strip around a steel frame. The manure scraper also has star wheels on the side. This allows for the scraper to easily move along support posts and water pipes. This manure scraper requires no sideways guidance of the cubicle edge. The scraper is 9 cm tall, so it is no obstacle for the cows. The manure scraper is also available with one star wheel on the cubicle side and a 30cm shorter scraper on the feeding side. The manure scraper is adjustable using 4 adjustment bolts.

Low-emission floor

The slat scraper can also be used on a low-emission floor (Field – V floor)

3.2.2 Combi scraper straight model

The combi scraper consists of two types and can be applied to closed floors as well as low-emission floors.

Closed floor

This scraper can be used on any closed floor. A rubber strip is mounted under the scraper for properly cleaning the (concrete/asphalt/rubber) floor. The fully galvanised model allows intensive use. The scraper is guided in the floor. On the way up, the scraper has a sliding function and on the way back the scraper is open. This scraper can be supplied with side flaps and rubber.

Low-emission floor

This combi scraper has been developed in collaboration with a concrete manufacturer (several floors). This manure scraper is suitable for slotted floors. The slots in the floor elements separate urine from manure, resulting in lower emission compared to traditional slatted floors. The so-called tines on the scraper blade will clean the grooves. This scraper works in the same way as on a closed floor. This scraper can be supplied with side flaps and rubber.

3.2.3 Combi scraper V-shape model

This combi scraper is slightly buckled, the so-called V-shape. This will minimise the risk of the combi scraper getting stuck while passing a drainage groove. A rubber or plastic strip on the bottom of the combi scraper will thoroughly clean the 'low-emission' closed floor. The combi scraper also comes as a model used under discharge. Since this scraper keeps itself stable, guidance is not required. The function is identical to the function under 'straight model'. This scraper can be supplied with side flaps and rubber.



INFO

All manure scrapers are customer-specific. Adjustments to the scraper can be made upon request.

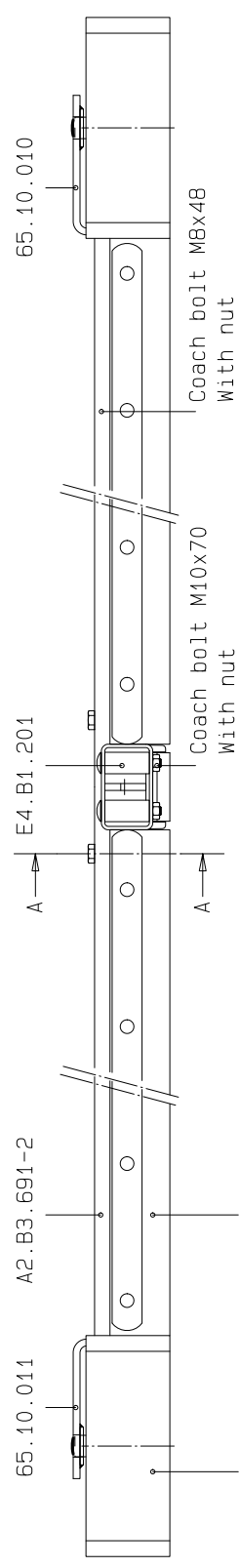
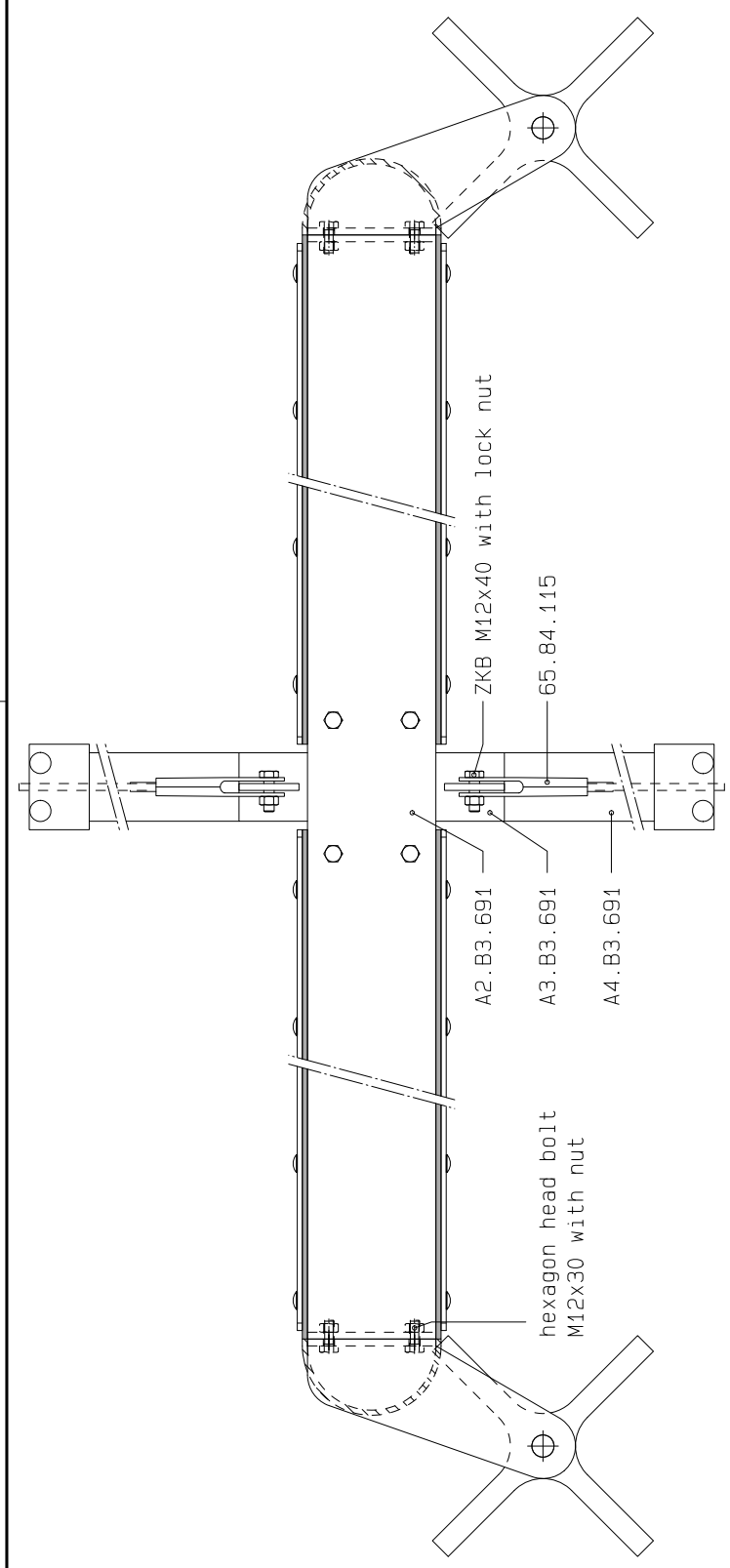

Scraper for grid floor with star-shaped wheels

Nr:	170-020	Blad nr:	1:1
Schaal:	1:5	Maateenh:	mm
Ger. nr:	0000		A3
Datum:	28-10-2014		
Get:	P.d.J.	Ger:	

- 71.12.071 hexagon tap bolt M12x70
- 83.12.150 washer M12
- 83.12.205 waved spring ring M12
- 82.12.100 hexagon nut M12
- 82.12.100 hexagon nut M12
- 82.12.100 hexagon nut M12

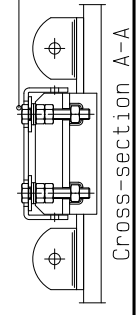

Tekening blijft ons eigendom en mag niet gepubliceerd, aan derden getoond of op andere wijze worden gebruikt.



Length of centre piece	800
Height of centre piece	200
Guide profile	UNP40x35
Guidance plate	geen
Length of bar	2590
Length of flap	1190
Length of clamping strip	1160

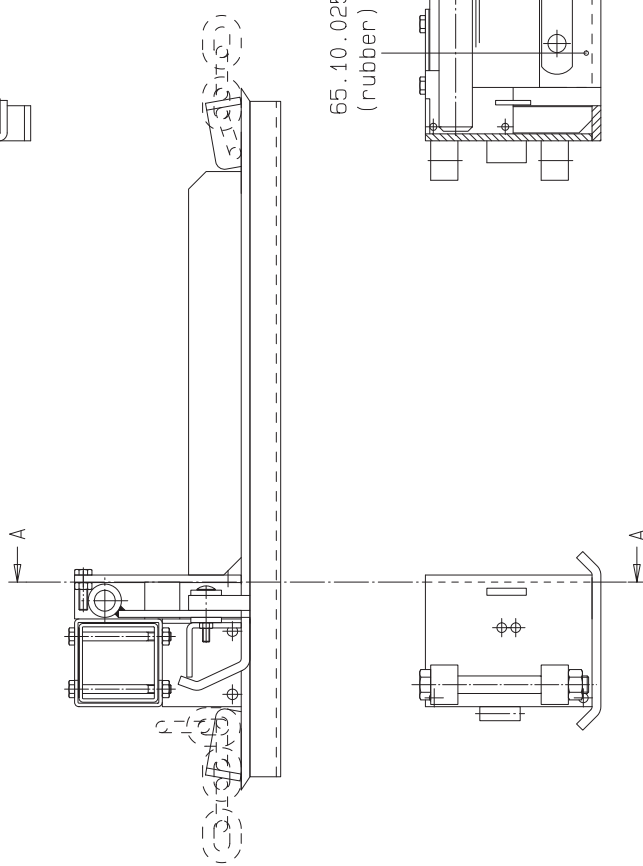
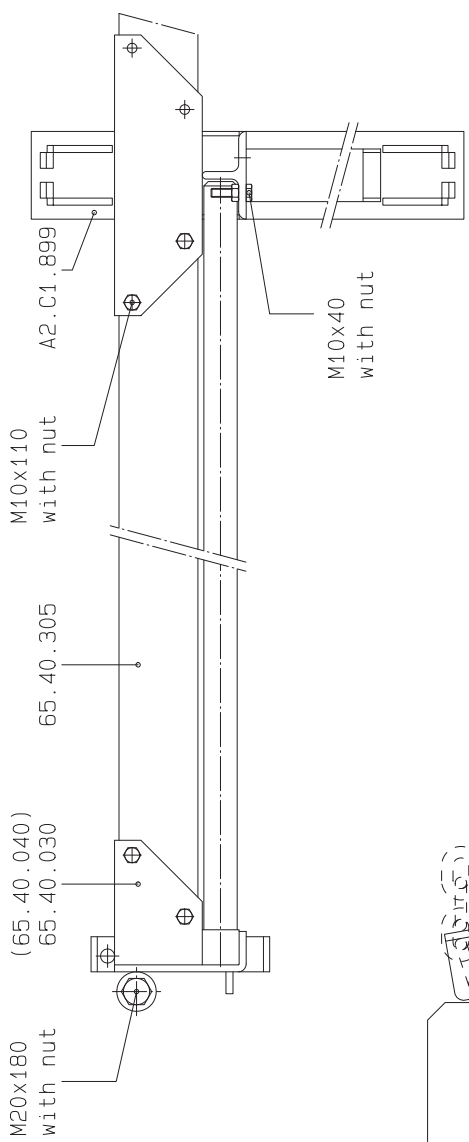

Cross-section A-A

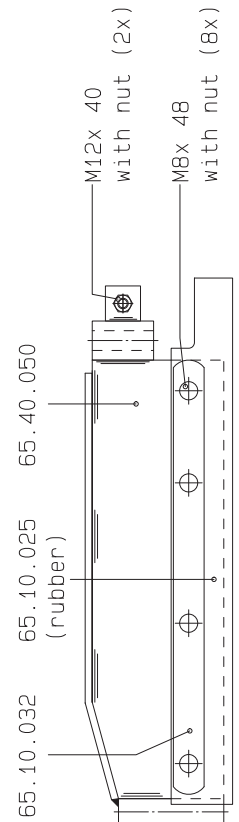

Combi scraper 300 chain spec.

Nr.:	A1C1899	Blad nr:	1:1
Schaal:	1:5	Maateenh:	mm
Ger.nr.:	0000	A3	
Datum:	28-10-2014	Get.:	P.d.J.
		Ger.:	

Tekening blijft ons eigendom en mag niet gereproduceerd, aan derden getoond of op andere wijze worden gebruikt.



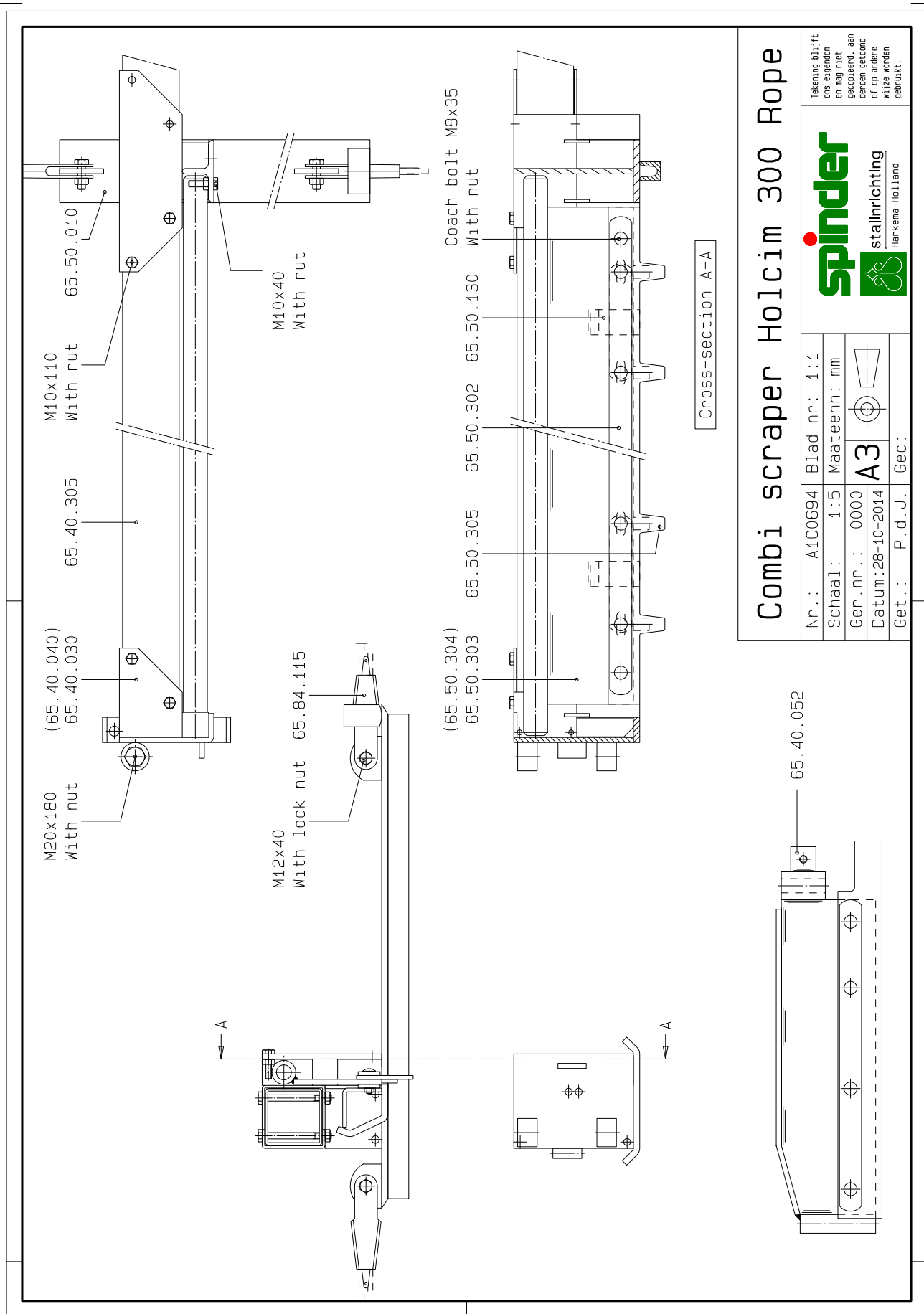

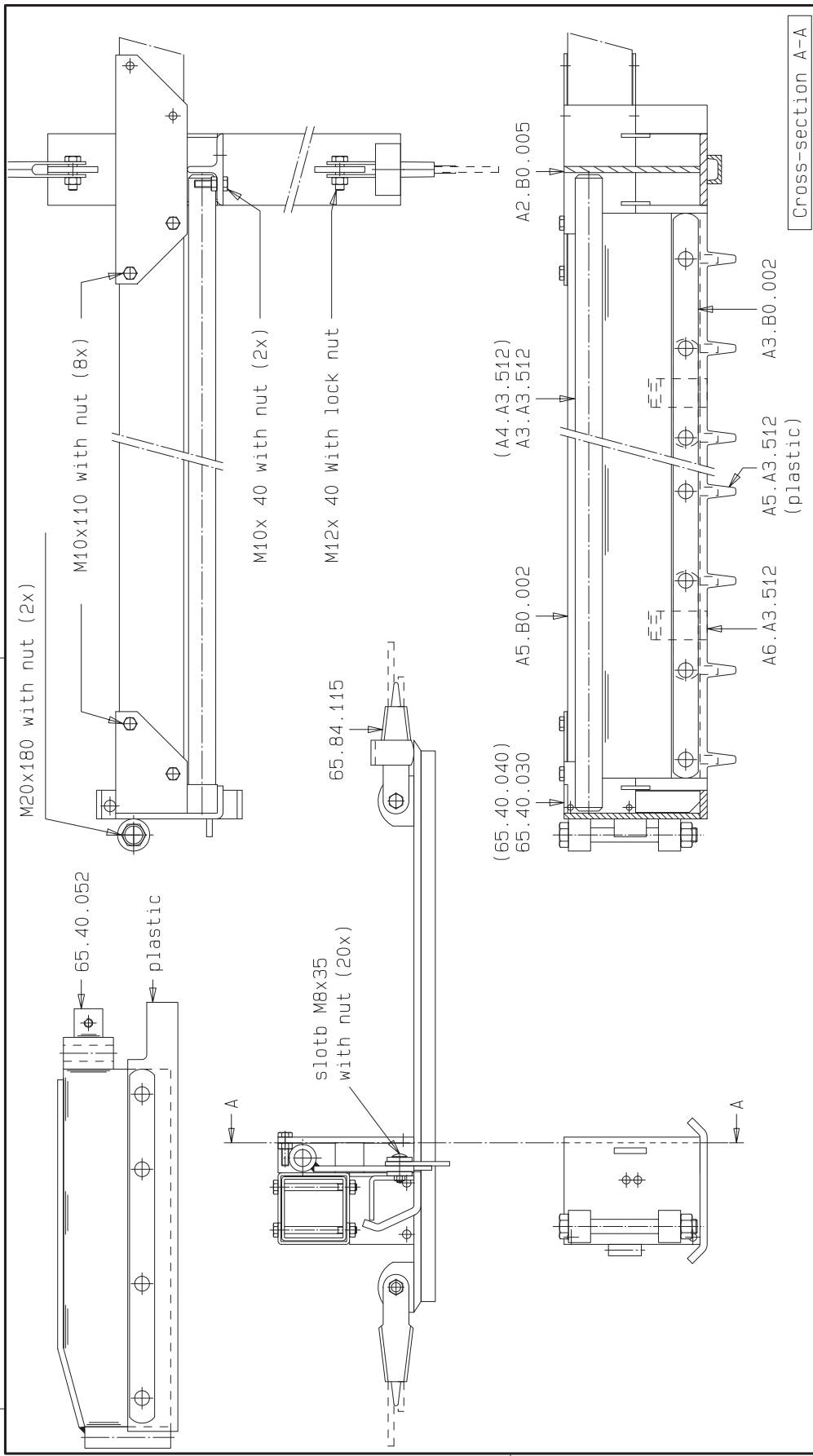

Combi scraper HoIcim 300 Rope

Nr.: A1C0694 Schaal: 1:5 Ger.nr.: 0000 Datum: 28-10-2014 Get.: P.d.J.		Blad nr: 1:1 Maateenh: mm A3 Ger.:		 stainrichting Harkema-Holland	Tekening blijft ons eigendom en mag niet gecopieerd, aan derden getoond of op andere wijze worden gebruikt.
Gec.:					



<p>Tekening blijft ons eigendom en mag niet worden gereproduceerd, aan derden getoond of op andere wijze worden gebruikt.</p>	
 stalinrichting Harkema-Holland	
Nr.:	A1B0002
Schaal:	1:5
Ger.nr.:	0000
Datum:	28-10-2014
Get.:	P.d.J.
Blad nr.:	1:1
Maateenh.:	mm
	
<p style="text-align: center;">Combi scraper Zeus 300 Rope</p>	

Length of centre piece	800
Height of centre piece	200
Guide profile	UNP40x20
Guidance plate	geen
Length of bar	2640
Length of flap	1215
Length of clamping strip	1215

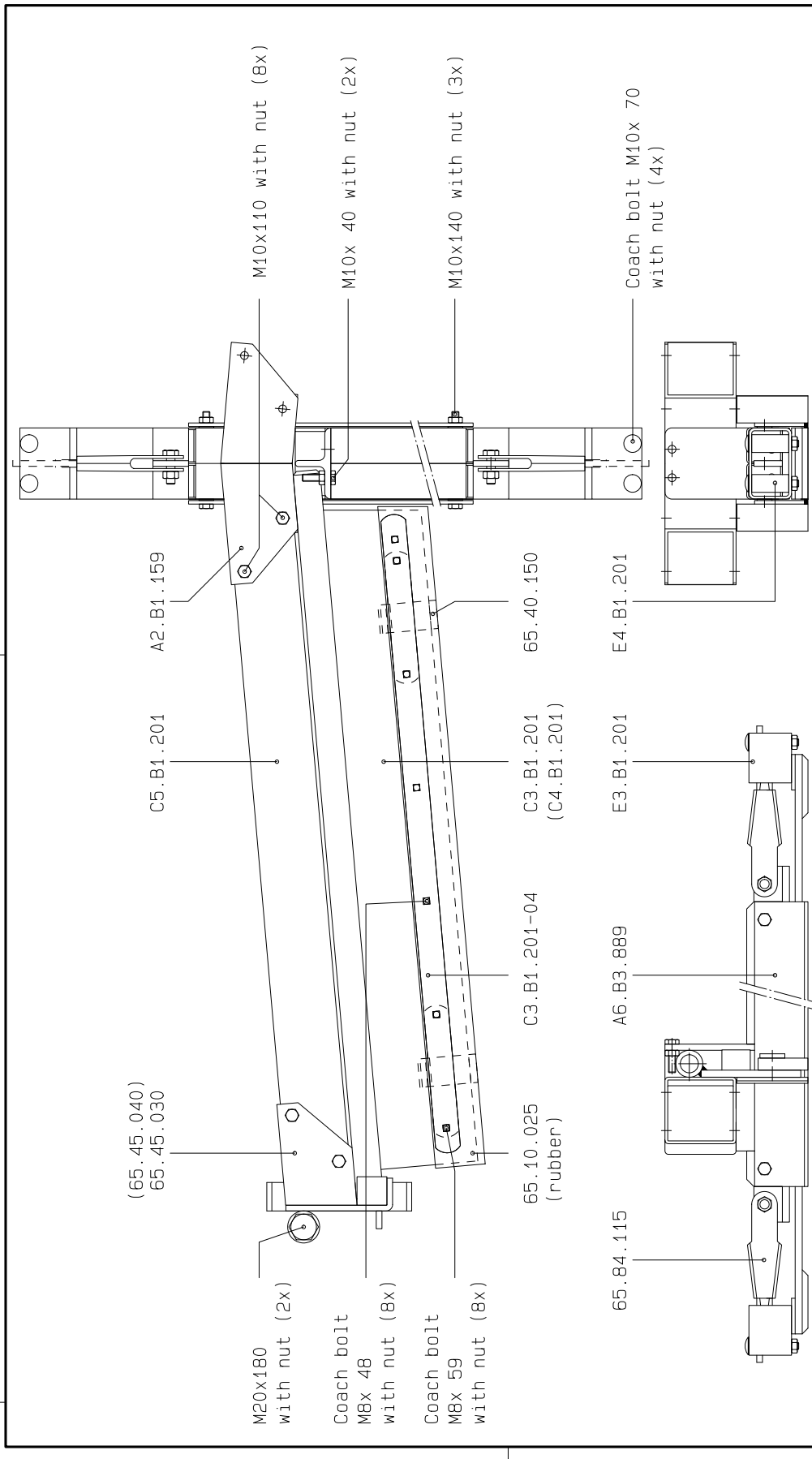

Combi scraper 300 V-vorm rope

Nr.:	A1B3855	Blad nr.:	1:1
Schaal:	1:5	Maateenh:	mm
Ger.nr.:	0000		
Datum:	29-10-2014		
Get.:	P.d.J.	Gec.:	



Tekening blijft ons eigendom en mag niet gecopieerd, aan derden getoond of op andere wijze worden gebruikt.

4 Assembly

4.1 Assembly of the drive units on the floor



INFO

Put the manure scrapers in the starting position (necessary for a combi scraper). This will determine the 'forward motor' ('forward motor' is the motor that pulls the manure scraper forward at the start).



PLEASE NOTE!

Only install the drive units on a concrete base floor or on a solid steel construction. The corner wheel and the unit should be at least 2000 mm apart. That is to evenly coil the cable onto the unit.

Remember the following points for the assembly of the drive motor:

- The height of the drive motor (recessed) (level of the channel in relation to the drive unit).
- Levelling.
- Distance corner wheel – drive unit (at least 2000mm), also if the scraper runs directly on the drive unit.
- Mount the drive unit in such a manner that the cable sits straight in front of the drive unit.
- Secure the drive units using 4 x M16 anchor bolts.

4.1.1 Assembly protective cover drive units on the floor



INFO

Make a hole in the protective cover to feed the rope. This should be 210 mm wide and 160 mm high. Deburr the edges afterwards.

- Mount the protective covers onto the drive units (M12 bolts and nuts).
- The entrance in the protective cover must be 0.5 cm in front of the protective cover of the drive unit. The protective cover sits in front of the hole in the protective cover of the drive unit. These protective covers are secured using M10 anchor bolts.



Drive unit on the floor
(Protective cover inlet not present!)



Drive unit mounted on floor

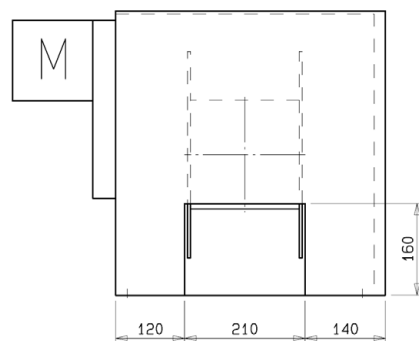

Dimensions for holes in the
Protective cover of the drive unit

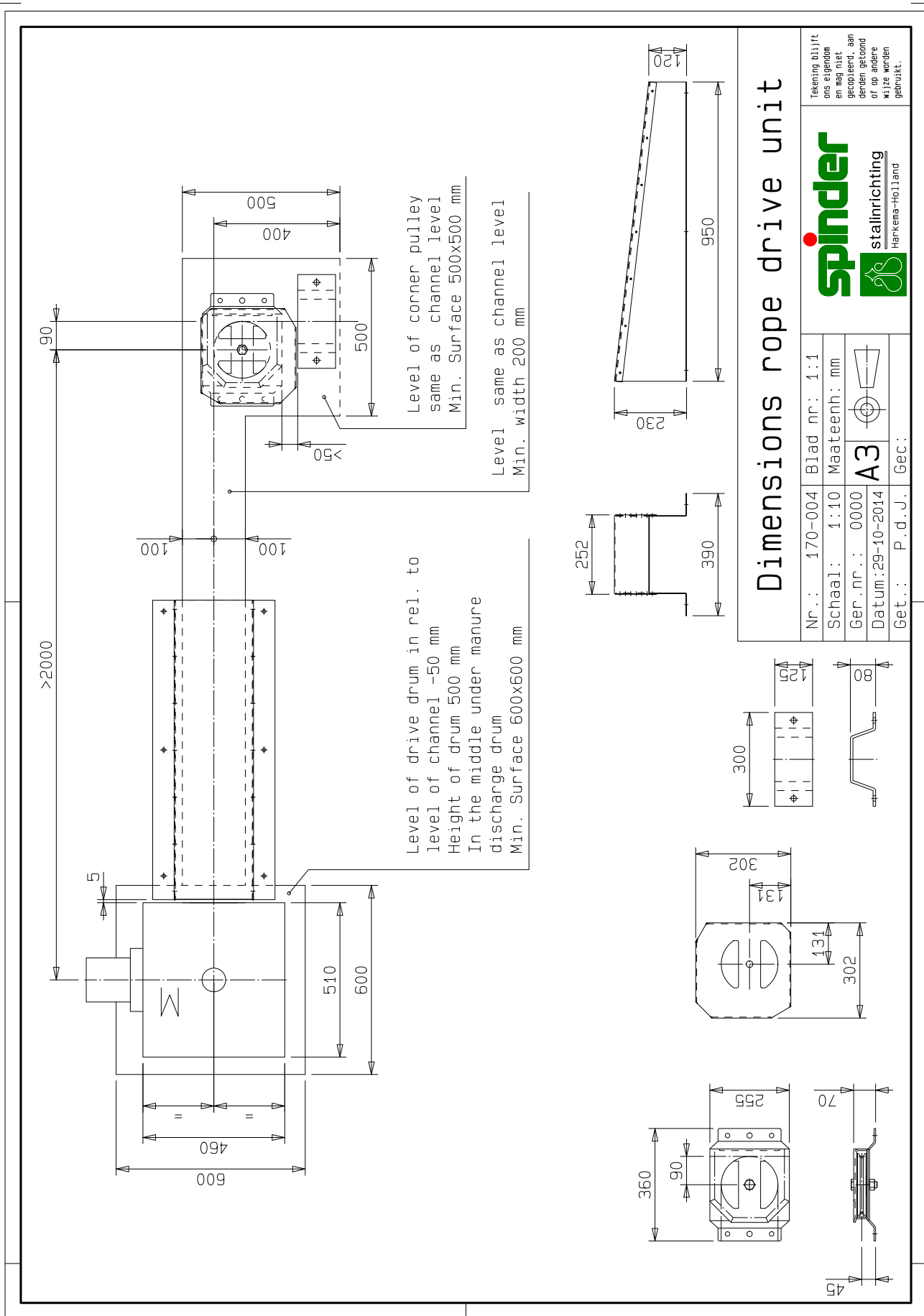

Dimensions rope drive unit

Nr.:	170-004	Blad nr.:	1:1
Schaal:	1:10	Maateenh.:	mm
Ger. nr.:	0000	A3	
Datum:	29-10-2014	Get.:	P. d. J.
		Gec.:	

Tekening blijft ons eigendom en mag niet gecopieerd, aan derden getoond of op andere wijze worden gebruikt.



4.2 Mounting the drive unit to the console



INFO

Put the manure scrapers in the starting position (necessary for a combi scraper). This will determine the 'forward motor' ('forward motor' is the motor that pulls the manure scraper forward at the start).



PLEASE NOTE!

Only install the drive units on a concrete base floor or on a solid steel construction.

The console is 2 metres long. The console contains a winding reel to run the rope to the unit. Mount the console onto a concrete floor, a concrete foundation or a slatted floor. The construction must be sufficiently solid.

The console can turn 360 degrees in relation to the drive unit. The rope runs completely screened off through the console to the drive unit.

Remember the following points for placement of the drive motor on the console:

- Placement of the frame for the drive unit on the console.
- Placement of the drive unit can be done in several ways; twisted, motor forward, motor backward, sides.
- Use T-irons for mounting the console onto the slatted floor.

4.2.1 Assembly protective cover drive units on console

- Mounting the protective cover (M12 bolts and nuts).



PLEASE NOTE!

For safety reasons, protective covers are supplied for free. Attach the protective covers after placement of the console.



Drive unit on console with stop



Drive unit on console with corner wheel

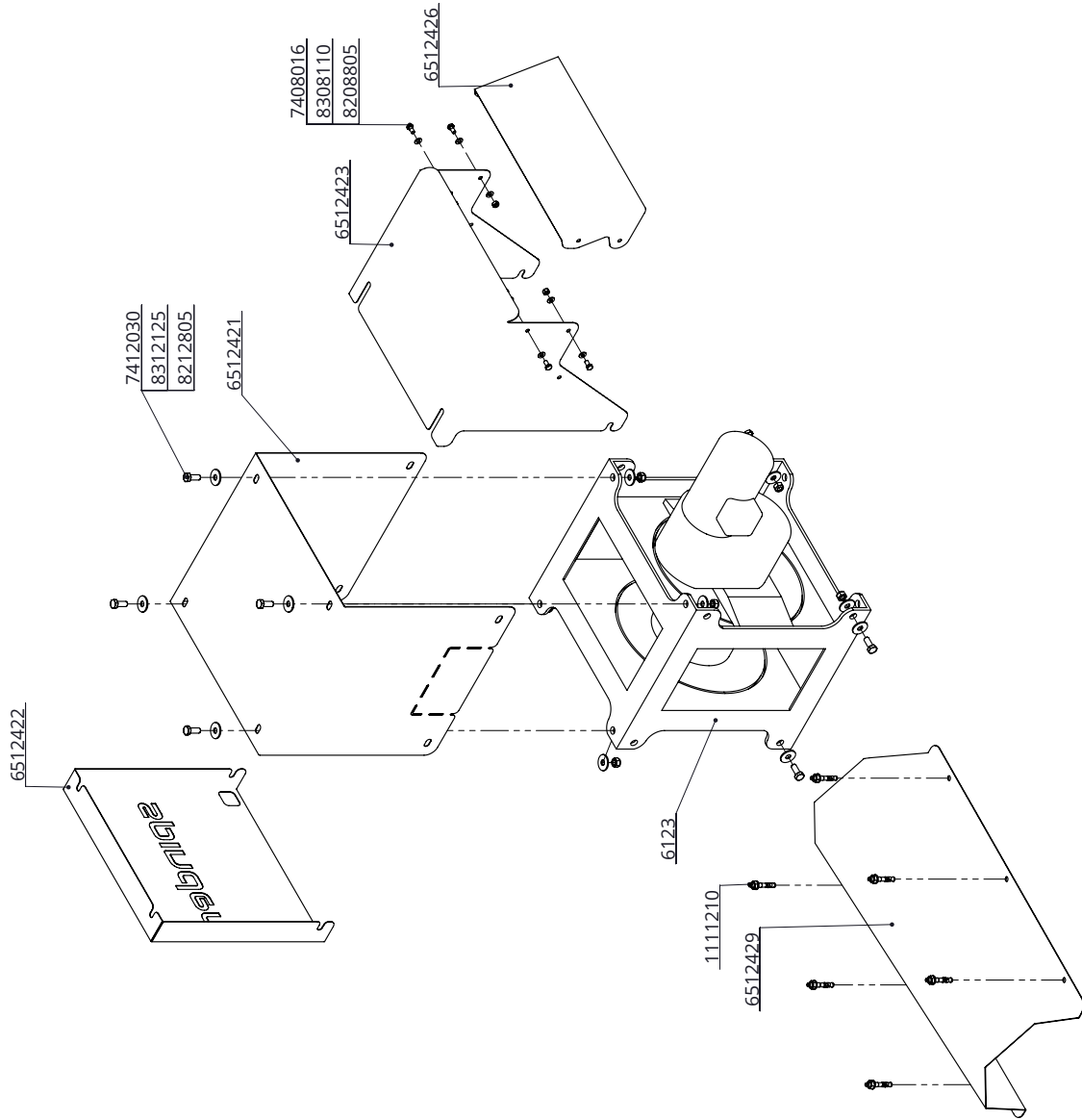

Bestel-nr.	Omschrijving	Aantal
1111210	betonanker, thermisch verzinkt - M10x71	6
6123	aandrijfunit	1
6512421	afdekkap RVS, trommel klein	1
6512422	afdekkap RVS, SPINDER klein	1
6512423	afdekkap RVS, motor klein	1
6512426	regenkap motor klein, RVS	1
6512429	beschermkap RVS, invoer touwaandrijving	1
7408016	zesk.tapbout M8x16 RVS	4
7412030	zesk.tapbout M12x30 RVS A2	8
8208805	zelfb. nylon moer M8 RVS	4
8212805	zelfb. nylon moer M12 RVS	8
8308110	sluitring M8 RVS	8
8312125	sluitring M12 (13x37x3) RVS	16

aandrijfstation PE-touw

 <small>DAIRY HOUSING CONCEPTS</small>	Nummer:	65124-O
	Maateenheid:	mm
	Datum:	19-1-2018

Tekening blijft ons eigendom en mag niet worden gekopieerd, aan derden getoond of op andere wijze worden gebruikt. Aan de gegevens op deze tekening, kunnen geen rechten worden ontleend.

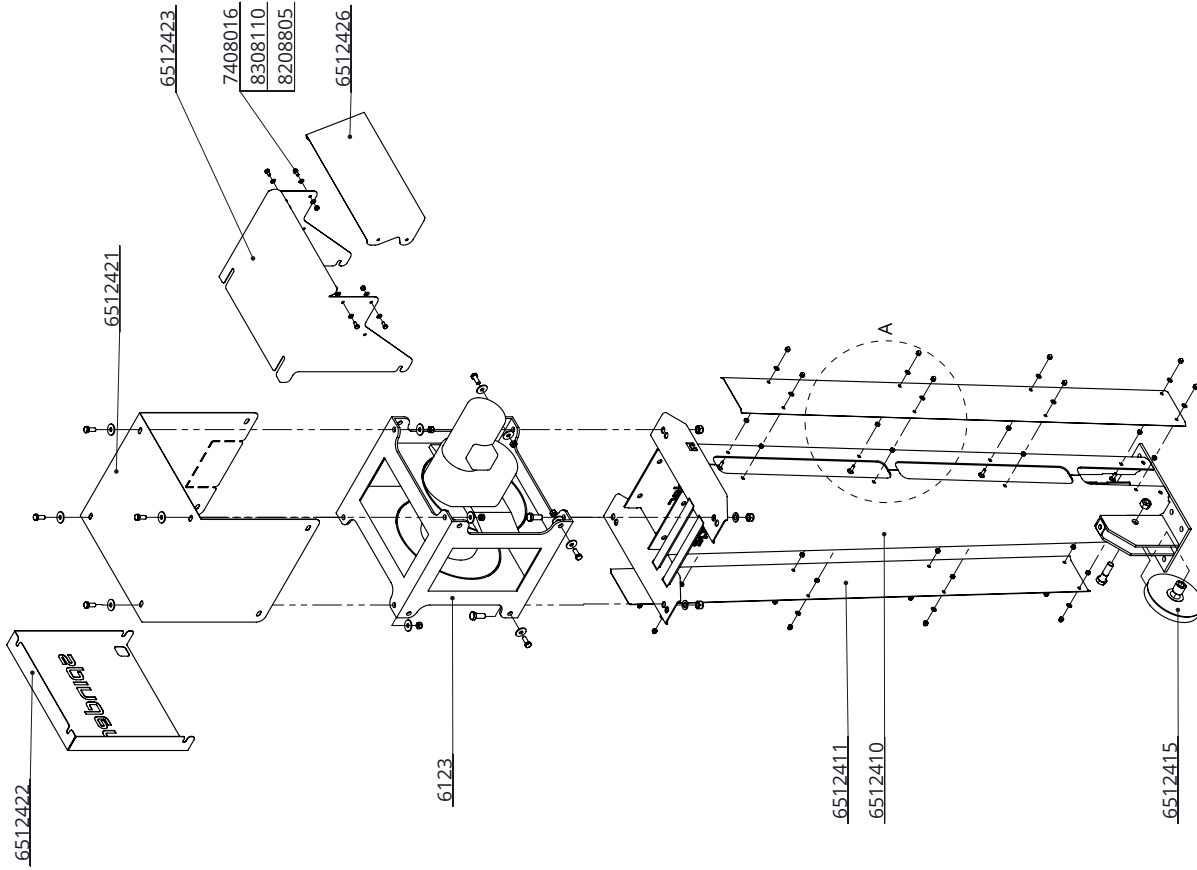

detail A (1 : 5)

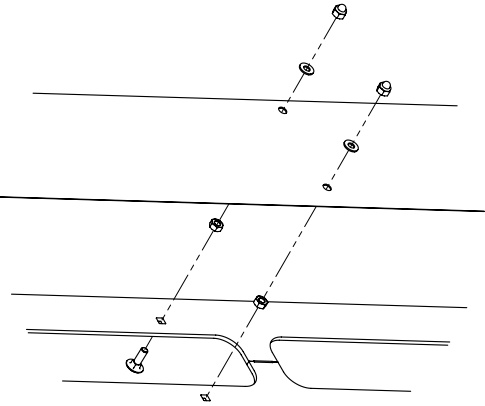

Bestel-nr.	Omschrijving	Aantal
6123	aandrijfunit	1
6512410	kolom trommelaandrijving universeel	1
6512411	afdekkap RVS, 1830x166mm voor console	2
6512415	mont.set trommelaandrijving op console	1
6512421	afdekkap RVS, trommel klein	1
6512422	afdekkap RVS, SPINDER klein	1
6512423	afdekkap RVS, motor klein	1
6512426	regenkap motor klein, RVS	1
7408016	zesk.tapbout M8x16 RVS	4
8208805	zelfb. nyloc moer M8 RVS	4
8308110	sluitring M8 RVS	8

aandrijfstation PE-touw

 DAIRY HOUSING CONCEPTS	Nummer:	65124-O
	Maateenheid:	mm
	Datum:	19-1-2018

Tekening blijft ons eigendom en mag niet gekopieerd, aan derden getoond of op andere wijze worden gebruikt. Aan het gegevens op deze tekening, kunnen geen rechten worden ontleend.

4.3 Mounting corner wheels



PLEASE NOTE!

Attach the corner wheels in a way that will ensure a solid construction. Check the correct assembly and the corner wheel guards. Not only when first putting it into operation, but also on a monthly basis. Keep the corner wheels clean to ensure their best possible performance.

Do not mount the corner wheels on any loose slats. In case there is no alternative way of mounting, make sure the slats cannot move from their fixed position. For other assembly points (such as on the console), also use a different mounting set. Make sure there is at least 2000 mm space between the cable entry of the corner wheel and between the cable entry and the drum. That is to evenly coil the cable onto the drum.

Remember the following points for the assembly of the corner wheels:

- Always place the corner wheel at the level of the channel.
- Assembly onto concrete floor: use 4 anchor bolts M12 x 106
- Assembly onto slatted floor: use 2 T-irons, M16 bolts.
- Loosen the plastic disc, loosen the bolt, run the rope through it and re-assemble.

4.3.1 Assembling the corner wheel protective cover

- Mounting the protective cover (PLEASE NOTE: sides are not equal).



PLEASE NOTE!

For safety reasons, a protective cover is supplied for free. Attach the protective covers after placement of the corner wheels.

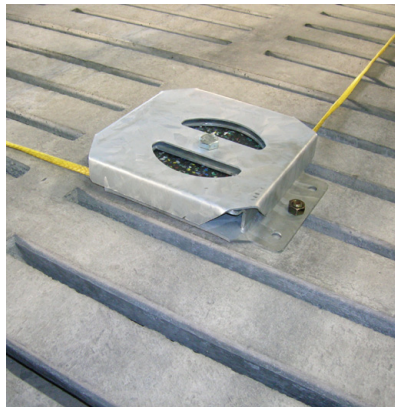



Corner wheel attached to slatted floor

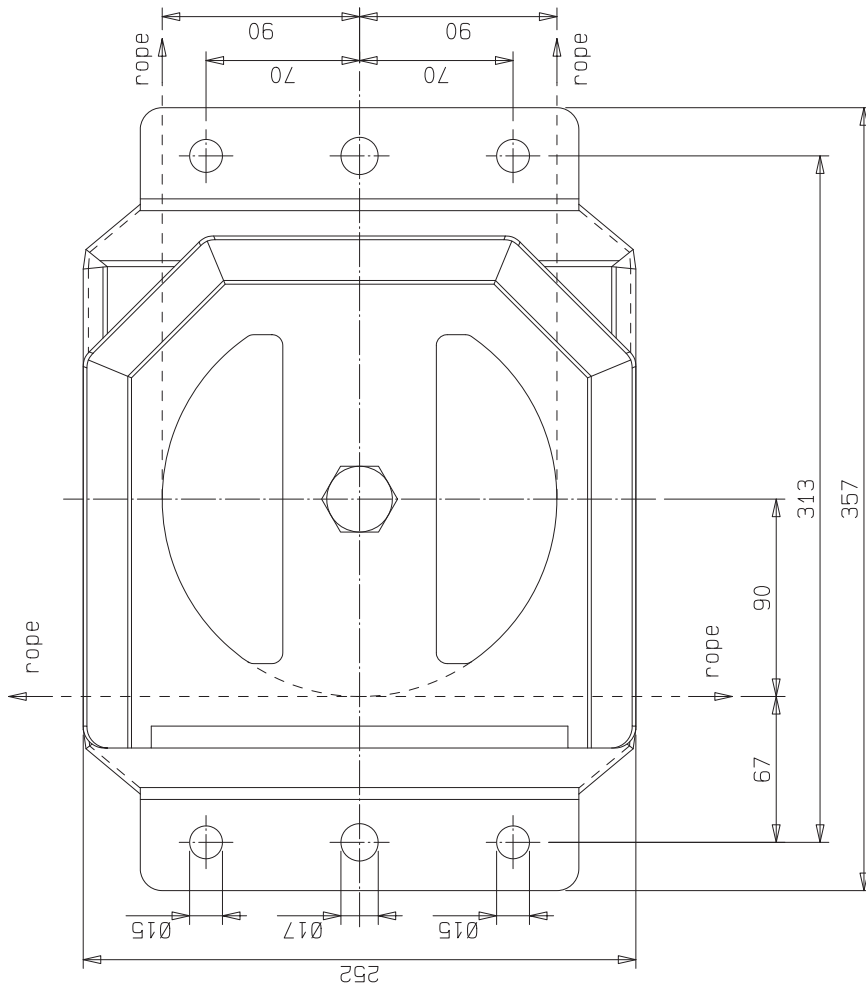
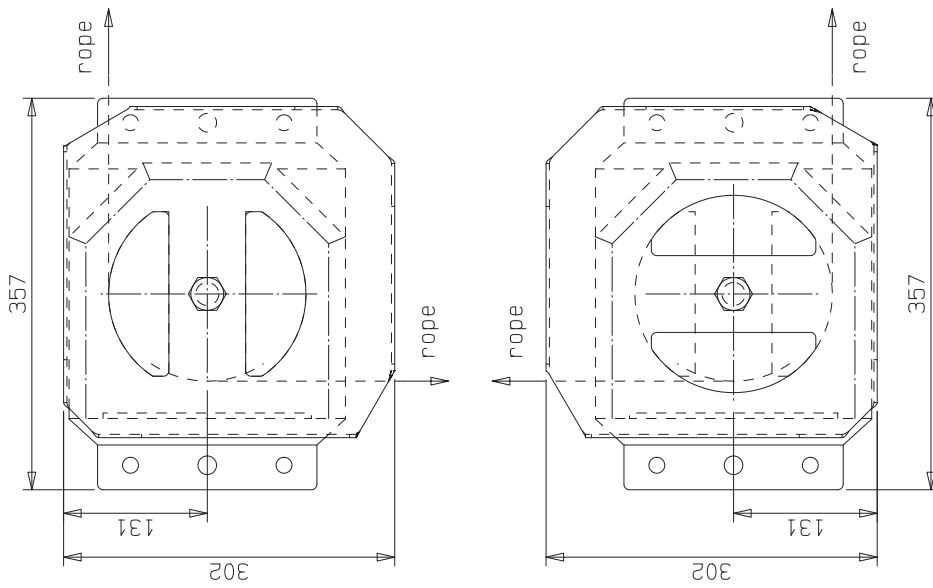

Corner wheel attached to concrete floor



dimensions corner pulley

Nr.:	170-008	Blad nr:	1:1
Schaal:	1:2	Maateenh:	mm
Ger.nr.:	0000	 A3	
Datum:	29-10-2014		
Get.:	P.d.J.		

Please note: Installation of protective cover
65.12.215 is necessary!

Tekening blijft
ons eigendom
en mag niet
reproduceerd, aan
derden getoond
of op andere
wijze worden
gebruikt.



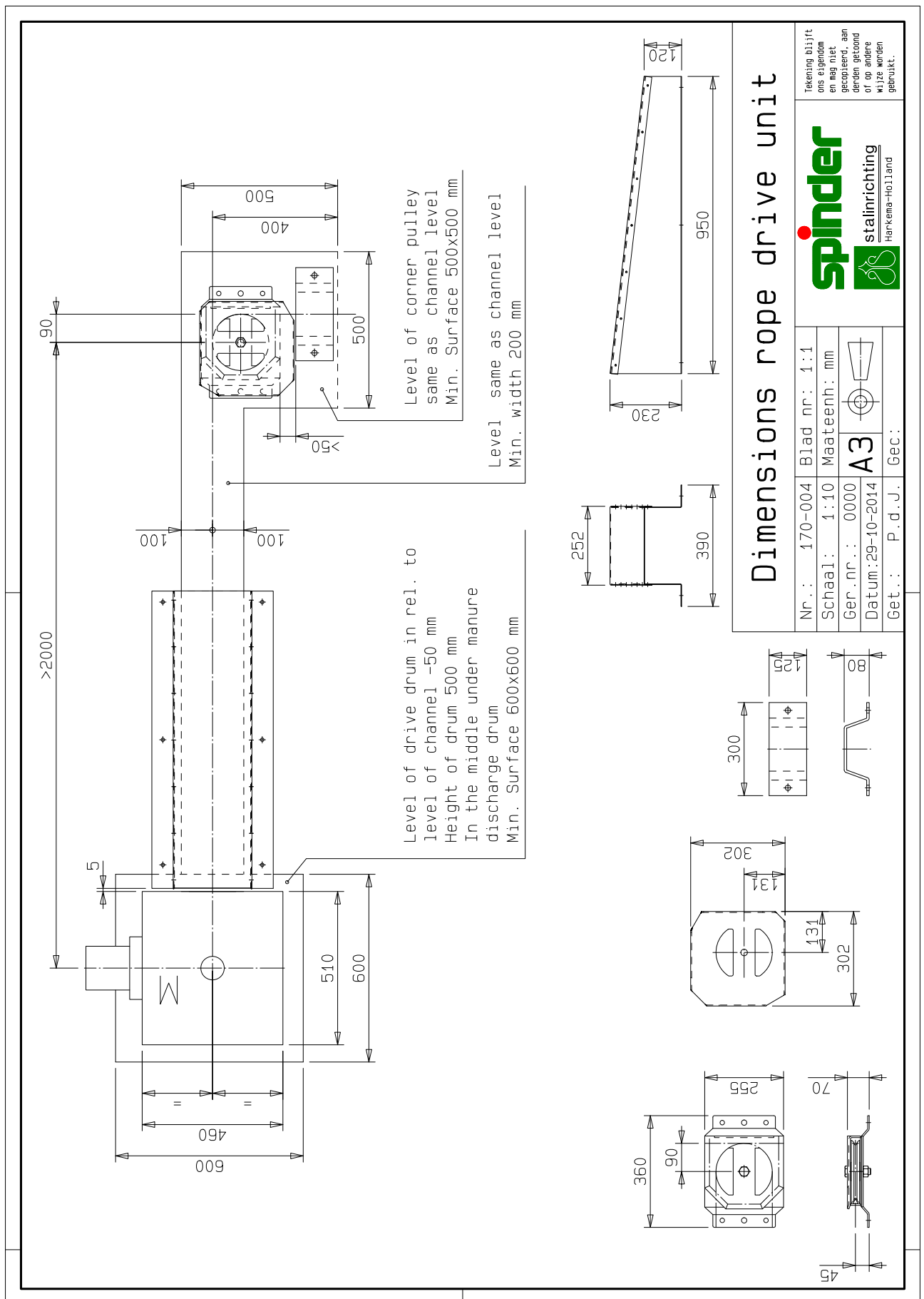

Dimensions rope drive unit

Nr.: 170-004		Blad nr: 1:1	
Schaal: 1:10		Maateenh: mm	
Ger. nr.: 0000		A3	
Datum: 29-10-2014		Ger.:	
Get.: P. d. J.		Gec.:	

Tekening blijft ons eigendom en mag niet gepubliceerd, aan derden getoond of op andere wijze worden gebruikt.



4.4 Assembly stop



PLEASE NOTE!

Attach the stop(s) in a way that the construction is sufficiently solid for maximum tensile load. Check the correct assembly of the stop(s) at the commencement of operation and subsequently every month.

The stop(s) is (are) required for determining the start and stop position. Assembly of the stop(s) may vary from the drawing since the stop(s) is (are) specifically placed. The stop(s) is (are) made of galvanised steel and they are maintenance-free.

Remember the following points for placement of the stops:

- Mounting onto concrete floor: 2 concrete anchors M16 x 120.
- Mounting onto slatted floor: 2 T-irons, M16.
- Place the stop as close to the corner wheel or drive unit as possible (>5 cm)
- Mount one stop with each motor.



INFO

For a V-shape model combi scraper without guidance we recommend the placement of two stops for each scraper



Stop attached to slatted floor



Stop for corner wheel



Stop attached to concrete floor

4.5 Assembling the discharge

The position of the discharge can be either halfway or at the far end of the channel. The required support for the scraper may differ for each floor type. These mounting instructions show the suggested build-in measurements (combi scraper straight and combi scraper V-shape) for the discharge, both inside and outside. They also show the measurements for the scraper support (combi scraper straight / Holcim / Zeus and combi scraper V-shape) above a discharge. Below are some examples of discharge supports.



INFO

Place a form of protection around the discharge (e.g. safety gates or grates). That is for accident prevention near the discharge. These gates or grates are available from Spinder Stalinrichting or your dealer.



Safety gate for discharge



Brick container on top of discharge

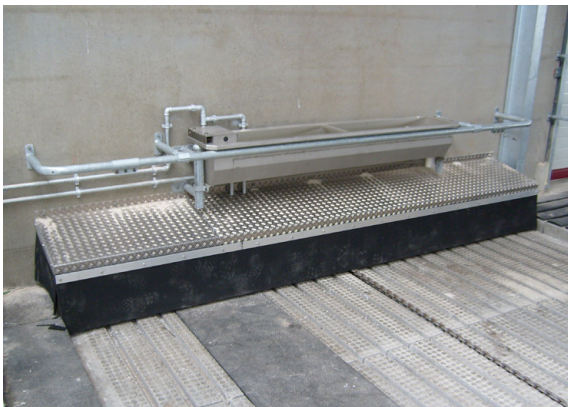

Safety gate and container for discharge



Safety gate for discharge with drinking trough



PLEASE NOTE

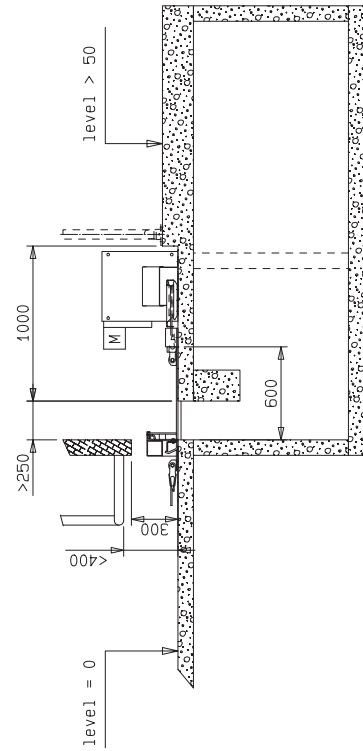
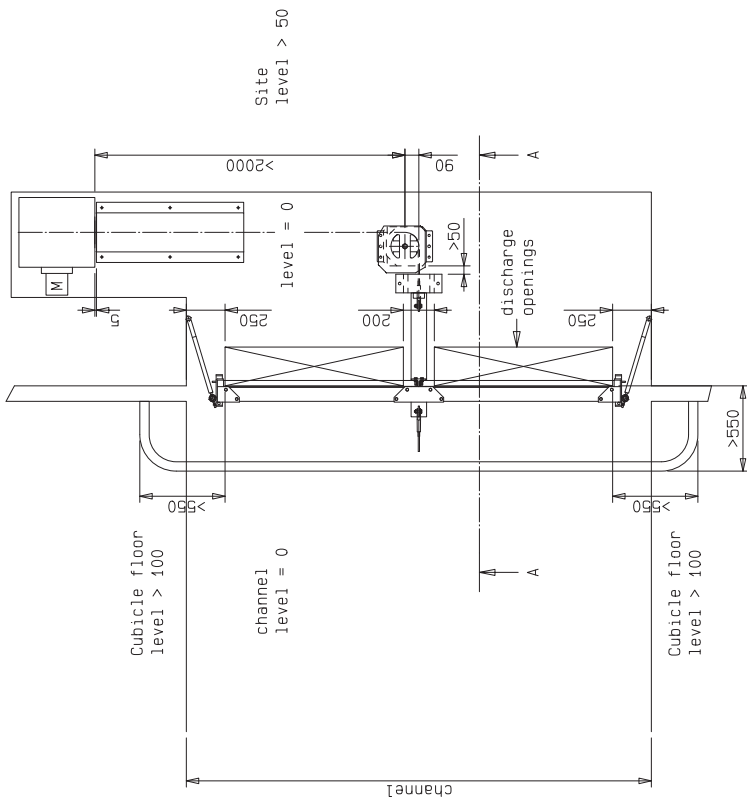

Suggested dimensions for safety fence for discharge, space between discharge and safety fence at least 55 cm! Make sure the discharge outside the barn is fully covered!



Cross-section A-A

Always shield the discharge opening well!
 Take precautions, so that no one can fall in!
 Shield the drums well against animal and people traffic!
 Contact Spinder for more information

Suggested dimensions for discharge outside

Nr:	170-023	Blad nr:	1:1	 Tekening blijft een eigendom van Spinder indien getoond of op andere wijze worden gebruikt.
Schaal:	1:20	Maateenh:	mm	
Ger. nr.:	0000	A2		
Datum:	29-10-2014	Get.:	P. d. J. Gec.:	

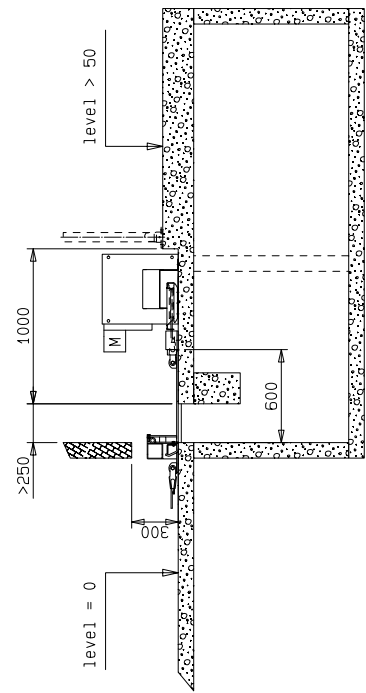
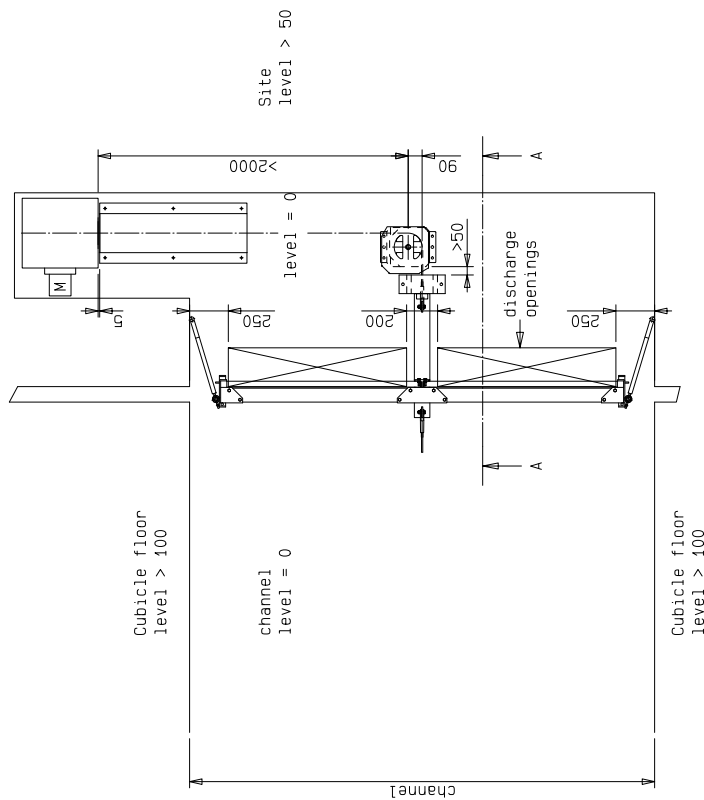

Cross-section A-A

Always shield the discharge opening well!
 Take precautions, so that no one can fall in!
 Shield the drums well against animal and people traffic!
 Contact Spinder for more information

Suggested dimensions for discharge outside

Nr:	170-006	Blad nr:	1:1	 <small>Tekening blijft geldig zolang er geen wijzigingen aan de tekening zijn aangebracht. Het is niet aan de tekening gebonden. Het is niet aan de tekening gebonden. Het is niet aan de tekening gebonden.</small>
Schaal:	1:20	Maateenh:	mm	
Ger. nr.:	0000		A2	
Datum:	29-10-2014	Get.:	P. d. J.	

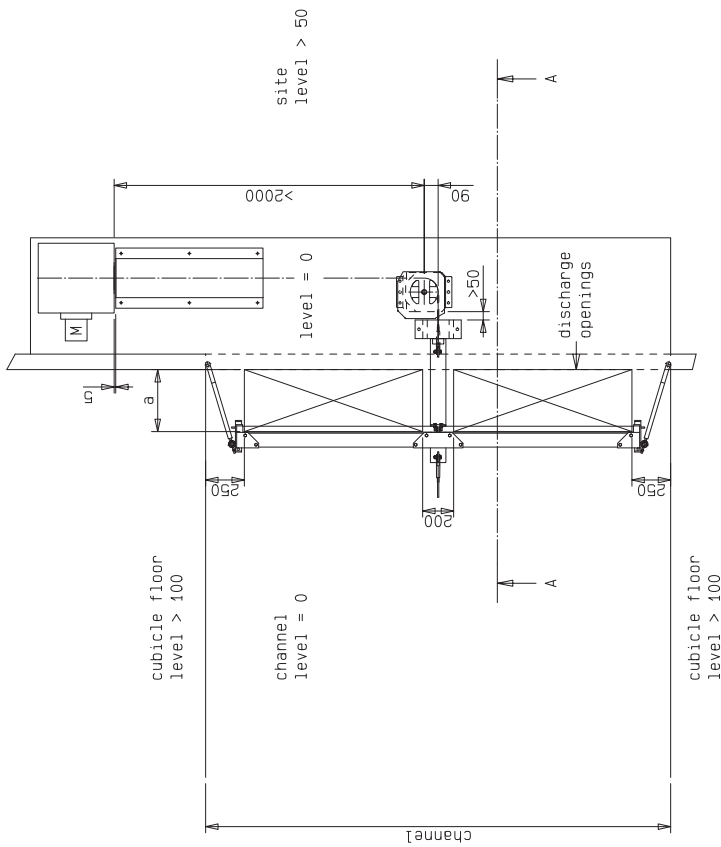

maat a	maat b	opmerking
250	1000	maat a minimaal
300	950	
350	900	
>400	850	

Always shield the discharge opening well!
 Take precautions, so that no one can fall in!
 Shield the drums well against animal and people traffic!
 Contact Spinder for more information

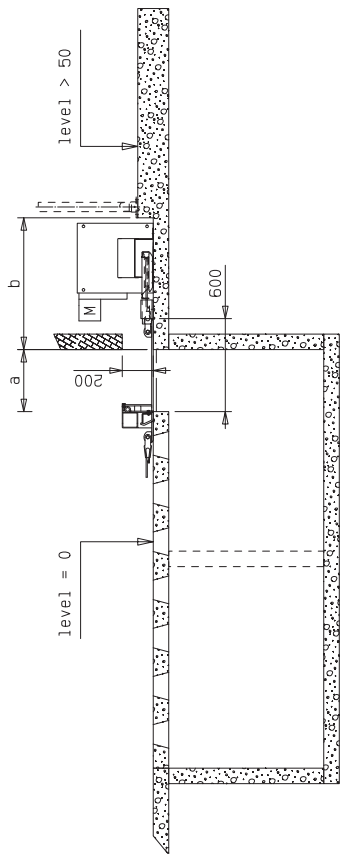

Cross-section A-A

Suggested dimensions for discharge inside

Nr:	170-012	Blad nr.:	1:1	 Tekening blijft ons eigendom en mag niet worden verspreid of op andere wijze worden gebruikt.
Schaal:	1:20	Maateenh:	mm	
Ger. nr.:	0000		A2	
Datum:	29-10-2014			
Get.:	P. B. J.	Gec.:		

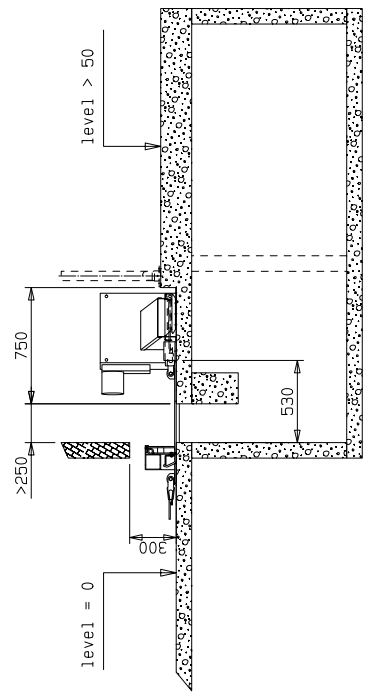
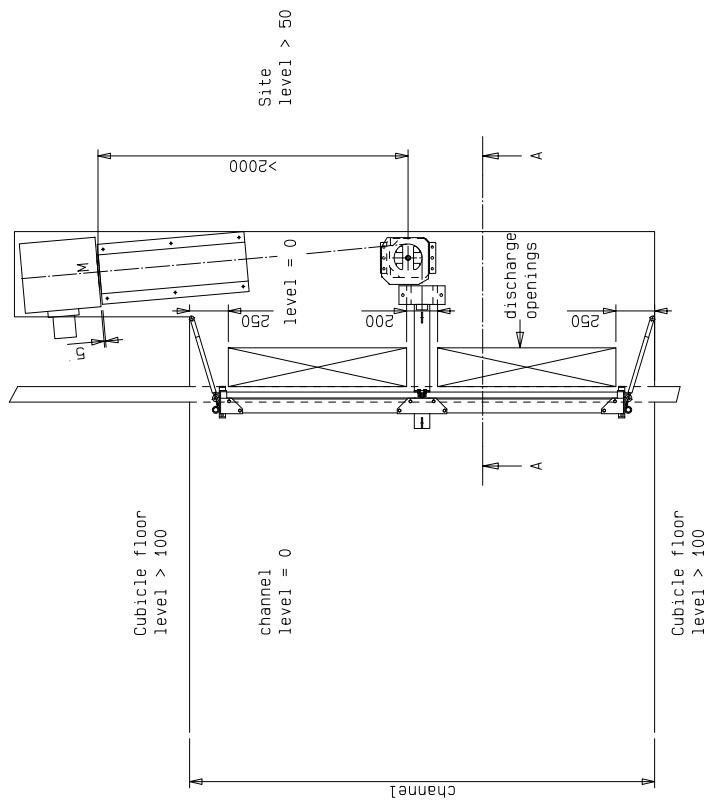

Cross-section A-A

Always shield the discharge opening well!

Take precautions, so that no one can fall in!

Shield the drums well against animal and people traffic!

Contact Spinder for more information

Suggested dimensions for discharge outside

Nr:	170-007	Blad nr:	1:1	 Teening blijft verboden en het niet geaccepteerd, als deuren getooid worden worden strafbaar gestraft.
Schaal:	1:20	Maateenh:	mm	
Ger. nr.:	0000		A2	
Datum:	30-10-2014			
Get.:	P. d. J.	Gec.:		

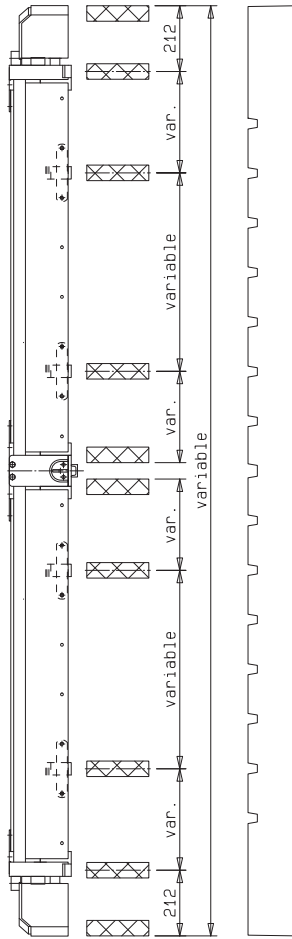
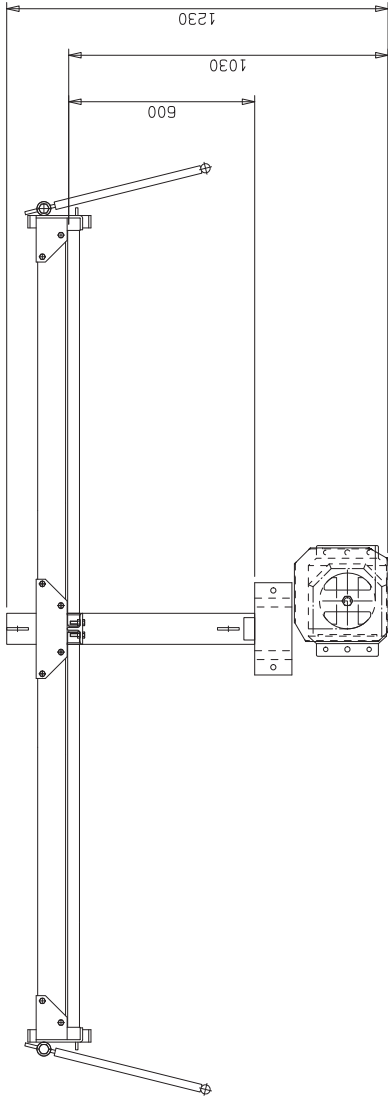

Note: Contact Spinder for more information

Suggested dimensions for discharge straight

Nr.:	170-014	Blad nr.:	1:1
Schaal:	1:10	Maateenh:	mm
Ger. nr.:	0000		
Datum:	30-10-2014		
Get.:	P. d. J.	Gec.:	

SPINDER
 stalmirroring
 Houtema-103 land

Tekening blijft
 ons eigendom
 en mag niet
 worden
 verspreid
 of op andere
 wijze worden
 gebruikt.

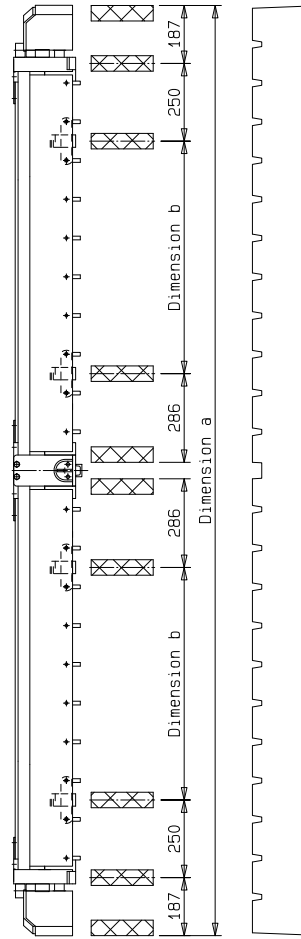
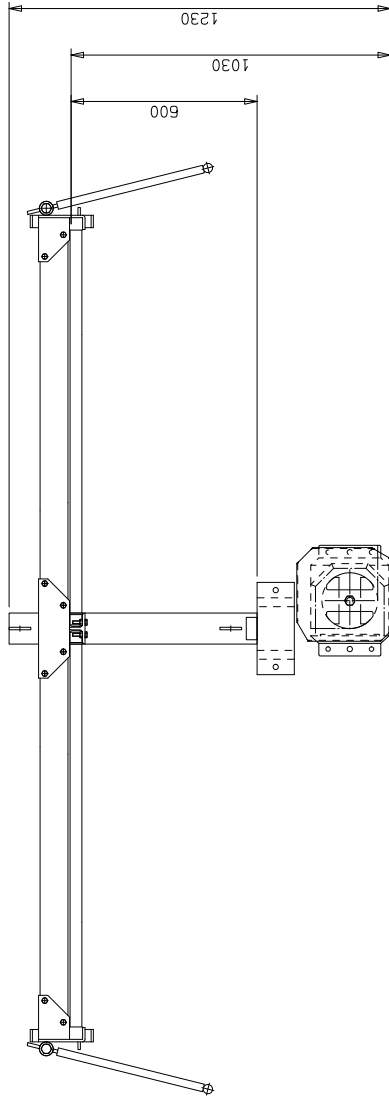

a	b
2500	500
2750	625
3000	750
3250	875
3500	1000
3750	1125
4000	1250

Please note: Width of support profiles 50 - 80 mm

Suggested dimensions afstortframe Zeus

Nr.: 170-009	Blad nr.: 1:1	 spinder stalmirroring Herkenbos-Hoiland
Schaal: 1:10	Maateenh: mm	
Ger. nr.: 0000	A2	
Datum: 30-10-2014	Get.: P. d. J.	

Tekening blijft
niet aansprakelijk
en mag niet
gecopieerd, aan
anderen getoon
of anderszins
in de openba
worden
gebruikt.

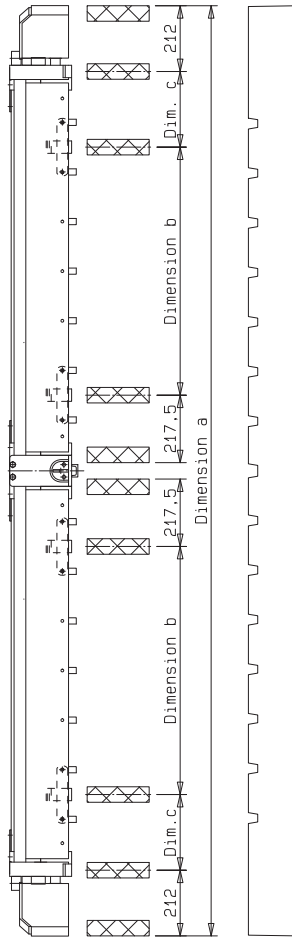
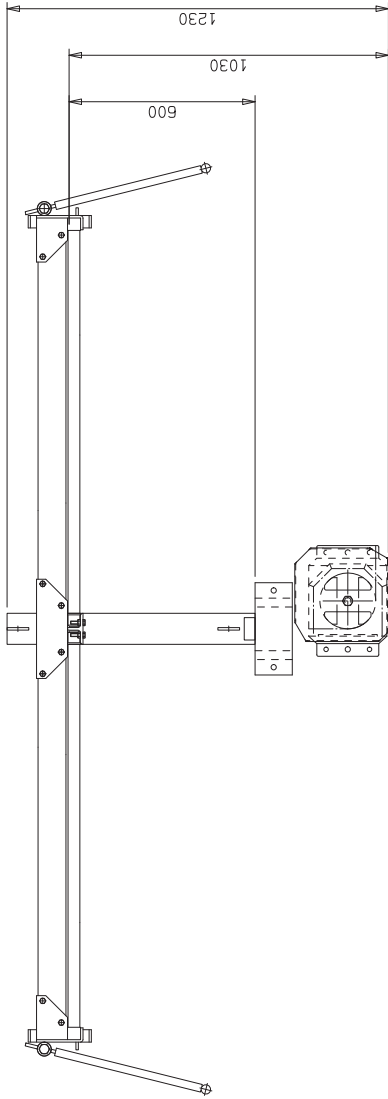

a	b	c
2000	320	224
2200	480	164
2500	480	314
2750	640	279
3000	800	244
3250	960	209
3500	1120	174
3750	1120	299
4000	1280	264

Please note: Width of support profiles 50 - 80 mm

Suggested dimensions afstortframe Holcim

Nr.: 170-013	Blad nr.: 1:1	Tekening blijft ons eigendom indien niet afgeleverd is of op andere wijze worden gebruikt.
Schaal: 1:10	Maateenh: mm	SPINDER
Ger. nr.: 0000		staalrichting
Datum: 30-10-2014	Get.: P. d. J.	HOLCIM-HOJLAND

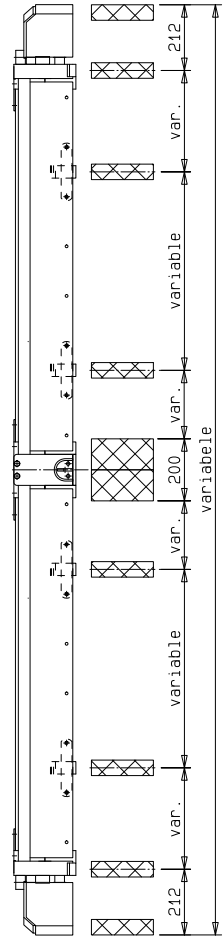
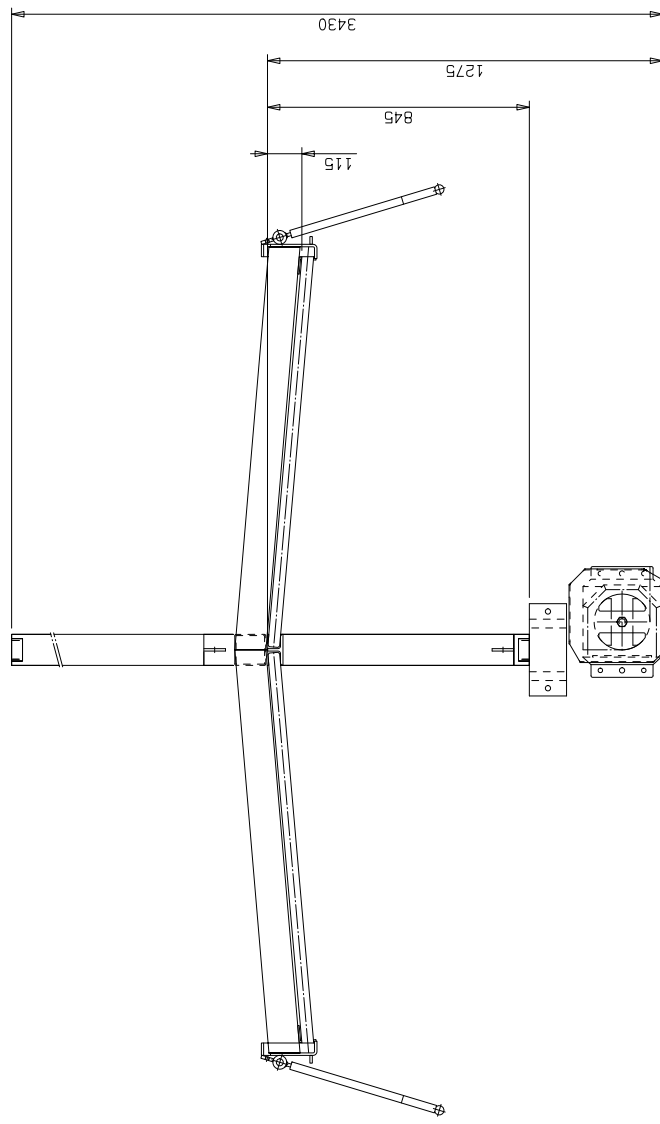

Note: Contact Spinder for more information

Suggested dimensions for discharge V-Vorm

Nr:	170-015	Blad nr:	1:1	 Tekenig blijft in bag niet gecolereerd, aan derden getoed als ze worden gebruikt.
Schaal:	1:10	Maateenh:	mm	
Ger. nr:	0000		A2	
Datum:	30-10-2014			
Get:	P. d. J.	Geç:		

4.6 Installing the control box

4.6.1 COMFORT control box

PLEASE NOTE! Remember the following points for installing the control box

- Mount the control box at a central, properly accessible place and in a solid position
- Do not expose the control box to direct extreme heat, cold or fluctuating temperatures
- Protect the control box against water entering and direct sunlight
- The power supply to the control box must have a lockable main switch next to the control box.
- Mount all necessary parts and fill every hole after installation
- Install emergency stop buttons at a level out of reach of the animals
- Install emergency stop buttons clearly visible and accessible
- Use approved cables and wires only; do not exceed the maximum cable length

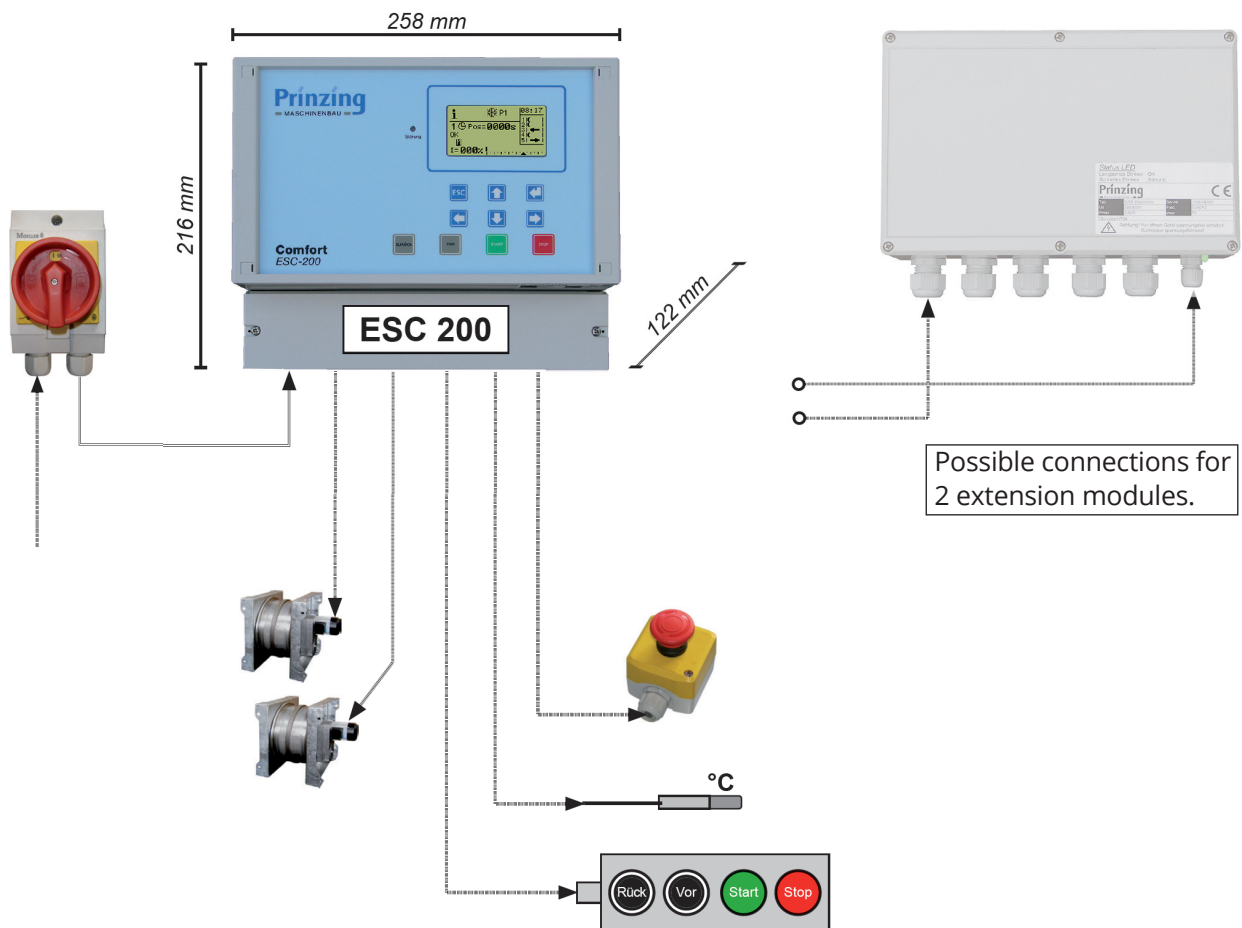

ESC 200

COMFORT - Steuerung / COMFORT-Controller

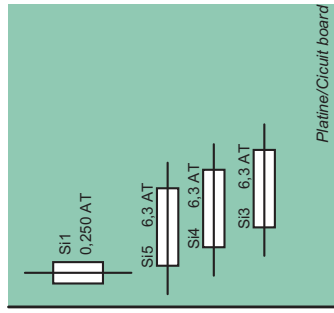

S1 - Sicherung Steuerung
 S3 - Sicherung Leistungsstrom
 S4 - Sicherung Leistungsstrom
 S5 - Sicherung Leistungsstrom

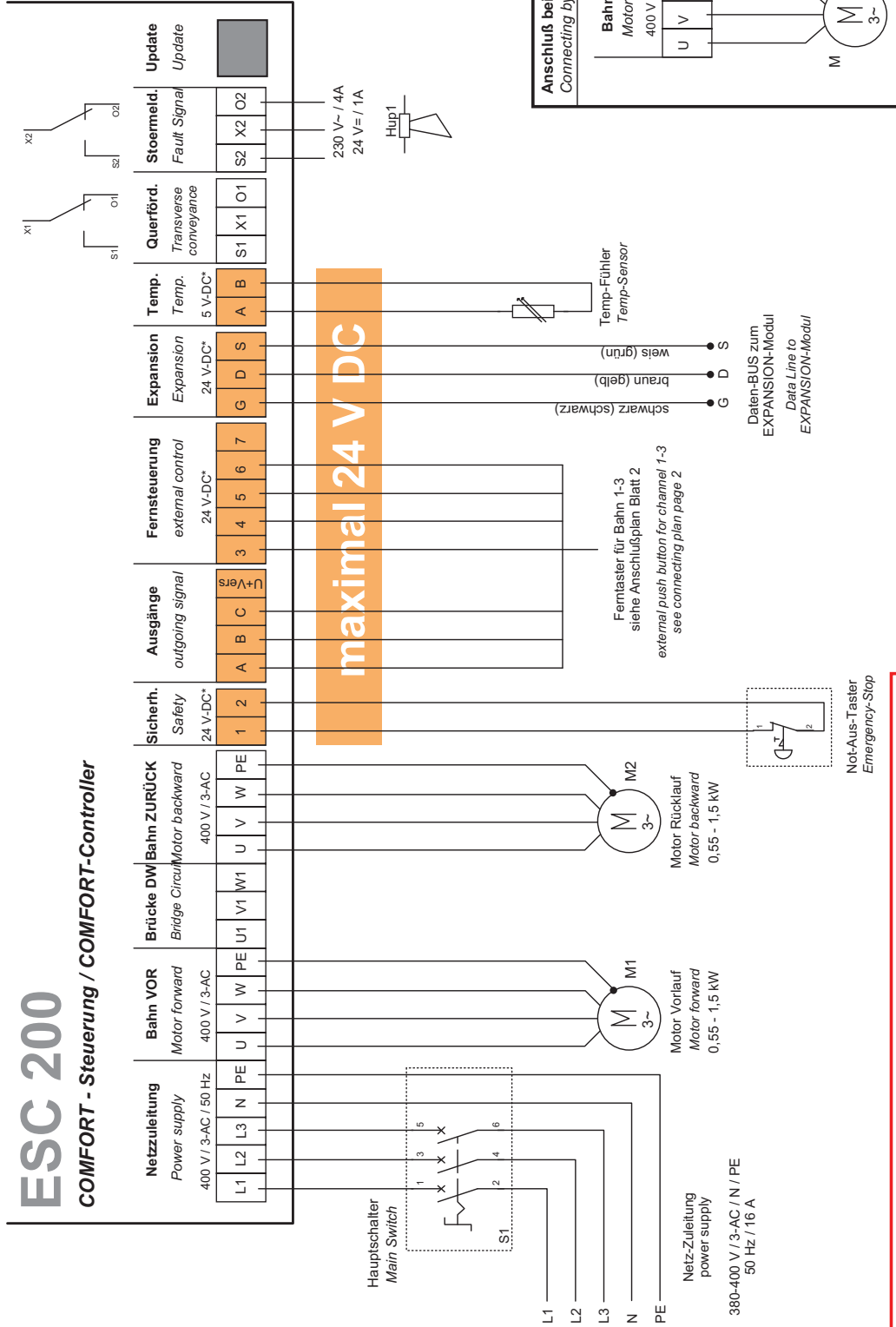

ACHTUNG! - ATTENTION!
 In die Zuleitung der Steuerung muß ein Hauptschalter montiert werden!
A main switch must be attached into the supply of the control!
 * = erfordert bei Messung externen Schließer gegen Masse
 = require external normally open contact at measuring against ground (mass)

Änderungen		Bezeichnung	
Datum	Name	Name	
22-03-2010	LHE		
24-02-2009	LHE	Anschlußplan ESC 200	
		Connecting plan ESC 200	
		Zeichnungs-Nr.: ESC200_ap_v03	
		Blattzahl:	3
		Blatt-Nr.:	1/3

Prinzing
 - MASCHINENBAU -
 Prinzing GmbH
 Siederhügel 2
 89173 Lonssee-Urspring
 Tel.: 0 7336 / 98 10-0

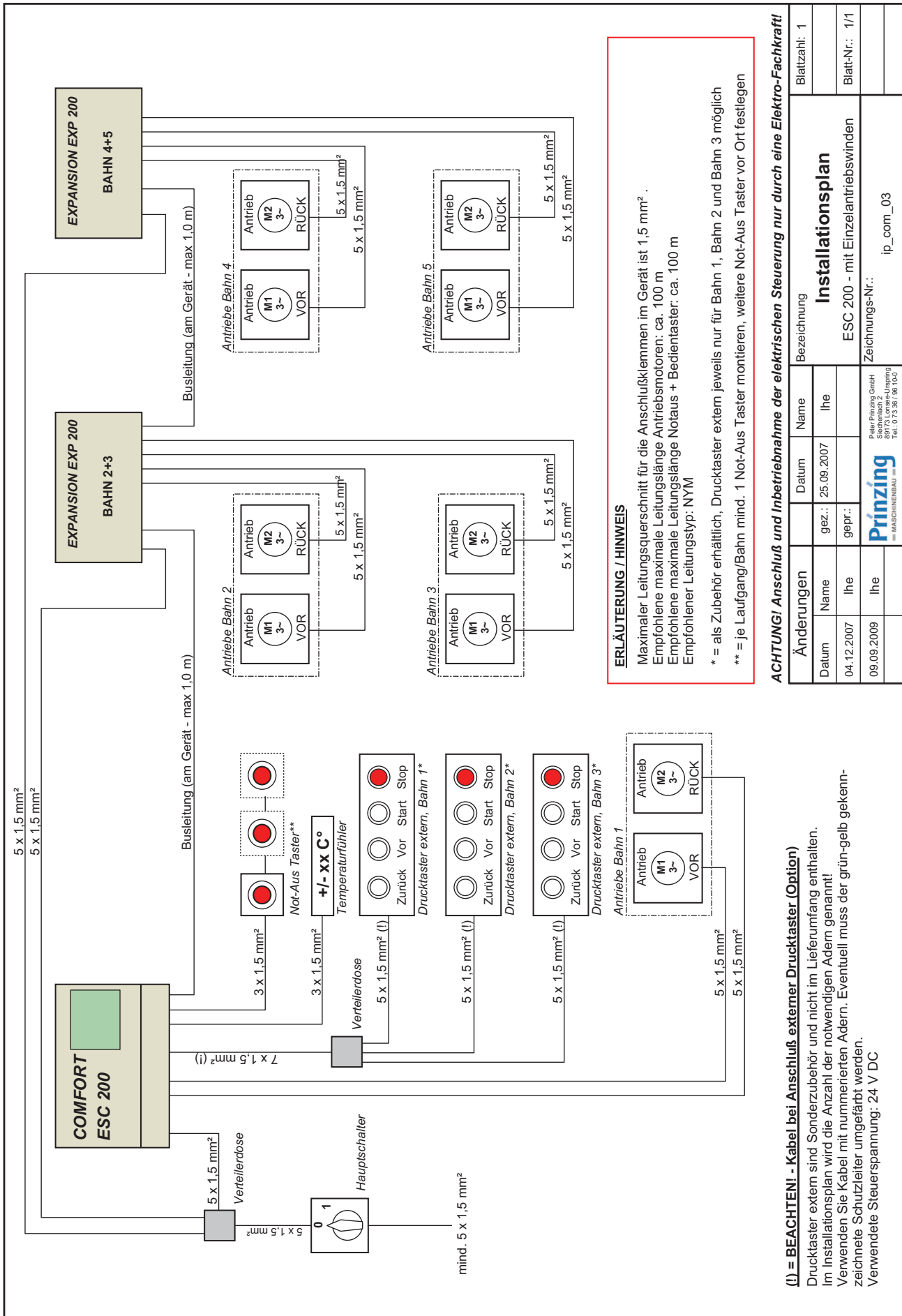

ERLÄUTERUNG / HINWEIS

Maximaler Leitungsquerschnitt für die Anschlußklemmen im Gerät ist 1,5 mm².
 Empfohlene maximale Leitungslänge Antriebsmotoren: ca. 100 m
 Empfohlene maximale Leitungslänge Notaus + Bedientaster: ca. 100 m
 Empfohlener Leitungstyp: NYM

* = als Zubehör erhältlich, Drucktaster extern jeweils nur für Bahn 1, Bahn 2 und Bahn 3 möglich
 ** = je Laufgang/Bahn mind. 1 Not-Aus Taster montieren, weitere Not-Aus Taster vor Ort festlegen

ACHTUNG! Anschluß und Inbetriebnahme der elektrischen Steuerung nur durch eine Elektro-Fachkraft!

Änderungen		Bezeichnung	
Datum	Name	Datum	Name
04.12.2007	lhe	25.09.2007	lhe
09.09.2009	lhe		

Installationsplan

ESC 200 - mit Einzelantriebswinden

Blattzahl: 1

Blatt-Nr.: 1/1

Zeichnungs-Nr.: ip_com_03

Prinzing
 Peter Prinzing GmbH
 Seidenbach 2
 91776 Lohr am Main
 Tel: 09381 90-100

(U) = BEACHTEN! - Kabel bei Anschluß externer Drucktaster (Option)

Drucktaster extern sind Sonderzubehör und nicht im Lieferumfang enthalten.
 Im Installationsplan wird die Anzahl der notwendigen Adern genannt!
 Verwenden Sie Kabel mit nummerierten Adern. Eventuell muss der grün-gelb gekennzeichnete Schutzleiter umgefärbt werden.
 Verwendete Steuerungsspannung: 24 V DC

ESC 200

Anschlussplan für Fern­taster an die ESC 200 (Bahn 1 bis Bahn 3)
Connection Plan for external push button on COMFORT-controller (Path 1 to Path 3)

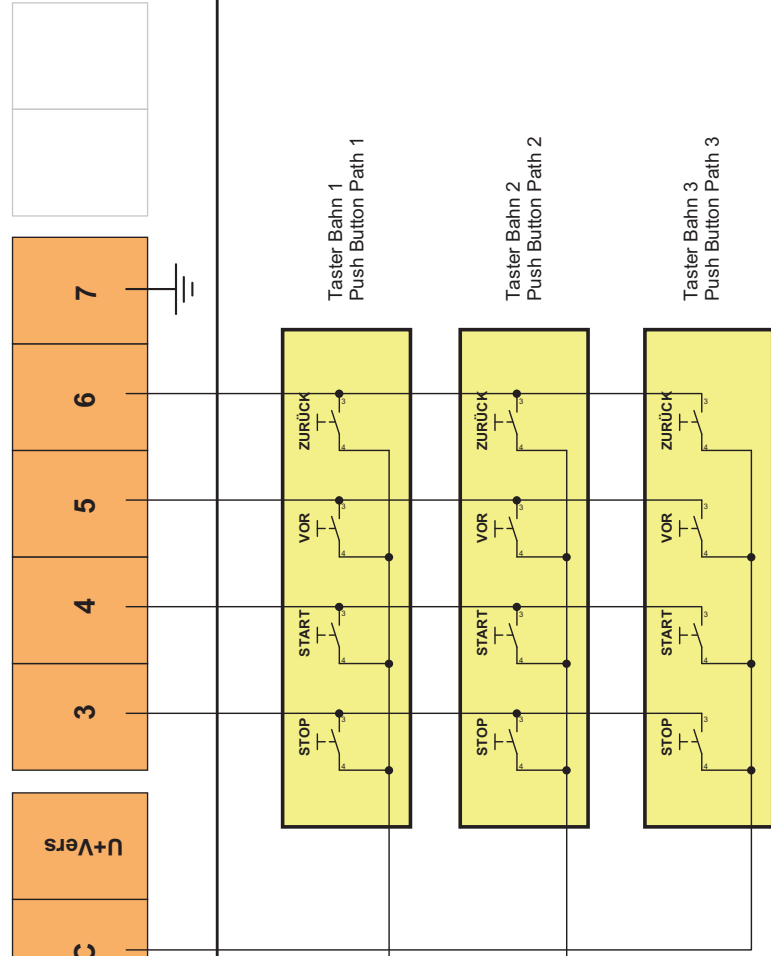

Anschlußleiste/Connecting block

HINWEIS

Anschluß-Spannung max. 24 V DC.
Keine Fremdspannung anlegen!

INFORMATION

Connected load max. 24 V DC.
Do not connect external voltage!

ACHTUNG! - ATTENTION!
 Taster für verschiedene Bahnen NICHT gleichzeitig drücken!
Don't push tracers for different gangway's at the same time!

Änderungen		Datum	Name	Bezeichnung		Blattzahl:
Datum	Name	gez.:	LHE	Anschlussplan ESC 200 <i>Connecting plan ESC 200</i>		3
22-03-2010	LHE	gepr.:				Blatt-Nr.:
				Zeichnungs-Nr.:		ESC200_ap_v03
				<small>Prinzing GmbH Maschinenbau 89172 Lohrwe-Jungfer Tel.: 07336/790100</small>		

COMFORT - Steuerung / COMFORT-Controller

Ausführung mit Einzelwinden / Specification with single winch

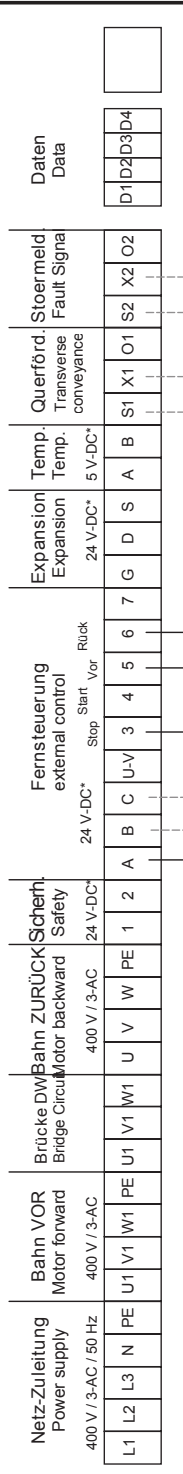

Anschluss an die entsprechende Bahn

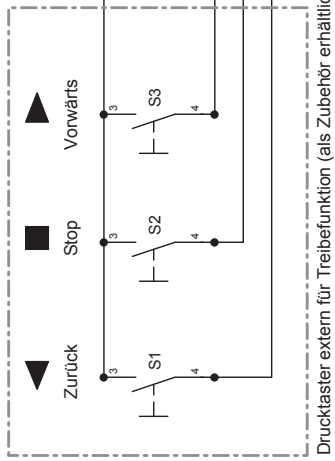

Wählen Sie einen freien Anschluss (S1 + X1 oder S2 + X2)
Eine genaue Beschreibung finden Sie in der Anlage "Treiben" zu Ihrer Bedienungsanleitung.

HINWEIS!
Leitungstyp:.....NYM Cat5 / Cat7
max. Leitungslänge:.....100 m
Steuerspannung:.....24 V DC

Die Treibfunktion kann auch mit angeschlossenem 4-fach Drucktaster verwendet werden. (Anschluss 4-fach Drucktaster siehe Standardplan)

Änderungen		Datum	Name	Bezeichnung	Blattzahl:
Datum	Name	gez.: 19-01-2010	lne	ESC 200 - Anschlussplan "Treiben"	1
		gepr.:		Connecting plan ESC 200 - "drive"	Blatt-Nr.:
				Zeichnungs-Nr.:	1/1
				esc200_ap_treiben_v01	

Prinzing
Maschinenbau
Peter Prinzing GmbH
89173 Lohrsee-Urspring
Tel.: 0 73 36 / 96 10-0

4.6.2 Extension module (EXP 200)

The COMFORT control box has room for two extension modules (EXP 200). The extension modules allow for two channels each.

PLEASE NOTE the following points:

- Install the extension module next to the COMFORT control box
- Connect the extension module to the earlier set data cables only
- Power supply must be connected to the main switch
- PLEASE NOTE the setting of the codes on the extension module

A pilot LED is attached to the bottom of the extension module.

After engaging the system, the LED will signal as follows:

- Slow blinking >>> Correct connection
- Fast blinking >>> Faulty connection
- LED is off >>> Faulty connection



Uitbreidingsmodule EXP200



Controle LED
Uitbreidingsmodule

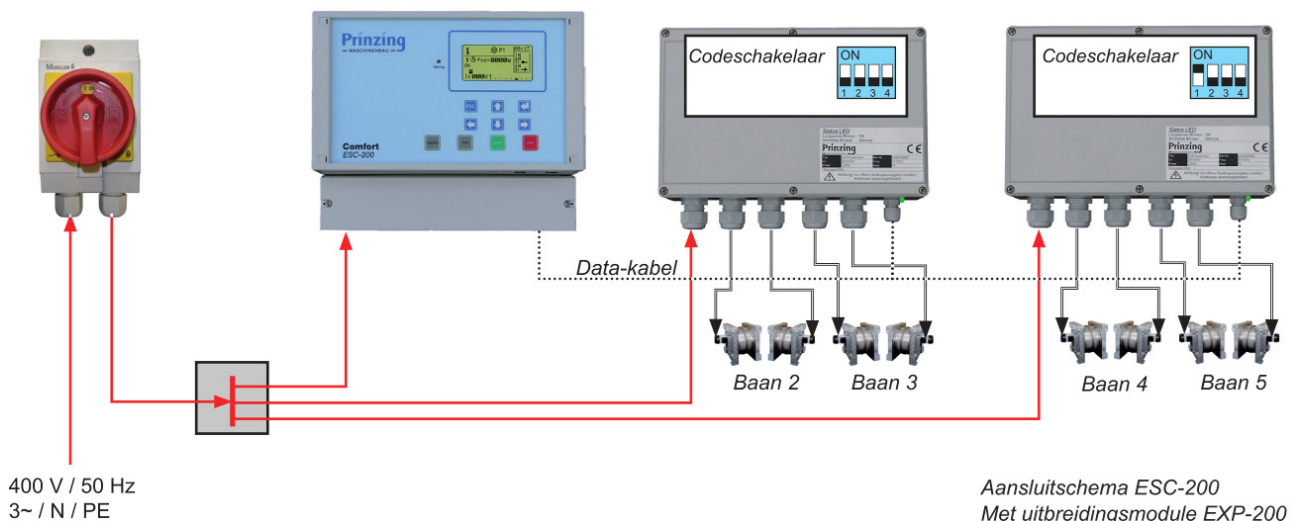

INFO

Incorrect setting of the code switch will result in the pilot LED being turned off; the display will show the error message "Error phase L1". Turn the code switch into the correct position and restart the control box.

EXP 200

EXPANSION - Erweiterungsmodul /Expansion module

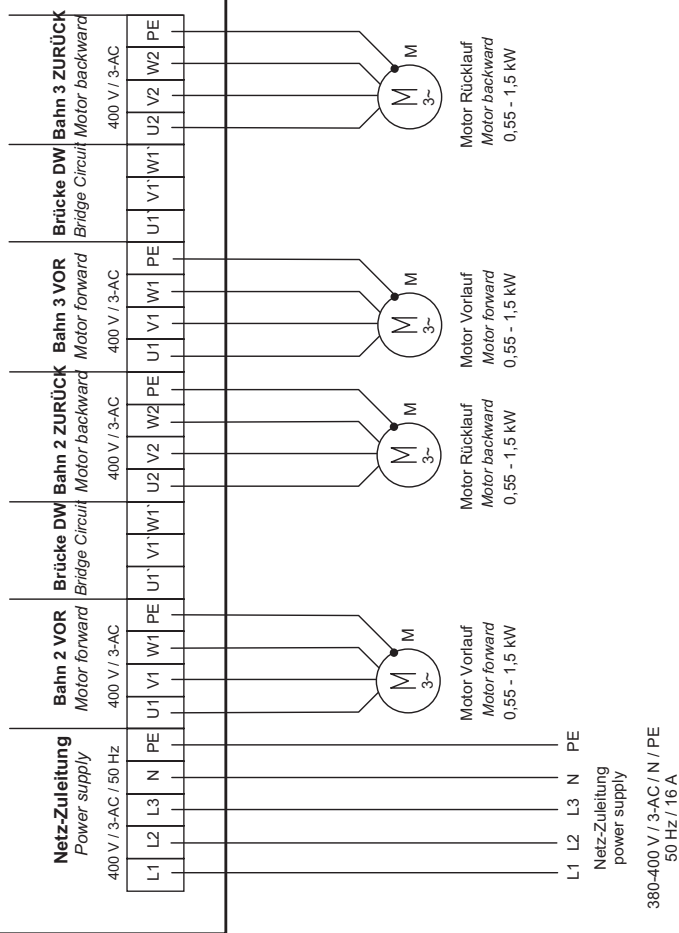

ACHTUNG! - ATTENTION!

Netzanschluß EXP 200 - Bei geringer Motorleistung:
 Zuleitung von Steuergerät und Expansion über gemeinsame Sicherung und Hauptschalter führt! (Abzeigb
 Netzanschluß EXP 200 - Bei hoher Motorleistung:
 Zuleitungen für Steuergerät und Expansions getrennt absichern und über jeweils einen Hauptschalter führen!

Power connection EXP 200 - At a low motor power:
 Supply of controller and expansion about common fuse and main switches carry! (connection box)
 Power connection EXP 200 - At a high motor power:
 Supplies of controller and expansion carry about separated fuse and one main switch each!

* = erfordert bei Messung externen Schließer gegen Masse
 = require external normally open contact at measuring against ground (mass)



Expansion Modul 1

Einstellung bei Verwendung von 1 EXPANSIONS-Modul (Bahn 2 - 3)
 Werkseinstellung
 Adjustment if using 1 EXPANSIONS-Module (Gateway 2 - 3)
 Factory made!



Expansion Modul 2

Einstellung bei Verwendung von 2 EXPANSIONS-Modulen (Bahn 4 - 5)
 An Exp.-Modul 2 einstellen!
 Adjustment if using 2 EXPANSIONS-Modules (Gateway 4 - 5)
 Set on Exp.-Module 2!

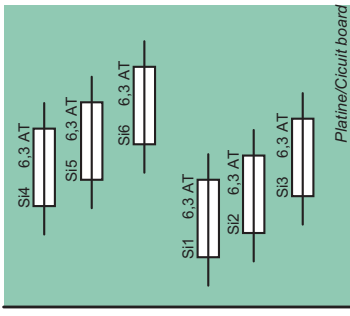
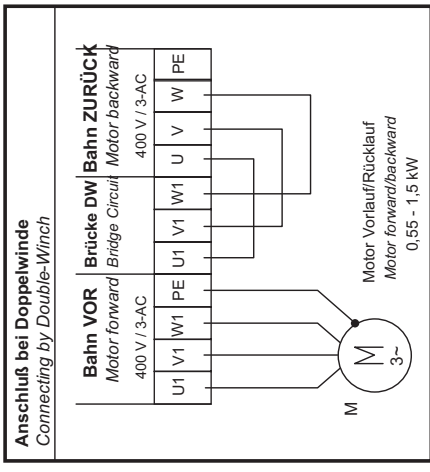

SI1-SI3 = Sicherung Leistungsstrom Bahn 2
 SI4-SI6 = Sicherung Leistungsstrom Bahn 3

Änderungen	Datum	Name	Bezeichnung	Blattzahl:
Name	24-02-2009	LHE	Anschlussplan ESC 200	3
Datum	22-03-2010	LHE	Connecting plan ESC 200	Blatt-Nr.:
			Zeichnungs-Nr.:	3/3
			ESC200_ap_v03	

Prinzing
 Peter Prinzing GmbH
 Industriestraße 1
 89173 Lohrwe-Üngers
 Tel.: 0 73 36 / 96 10-0

4.6.3 BASIC control box

PLEASE NOTE! Remember the following points for installing the control box

- Mount the control box at a central, properly accessible place and in a solid position
- Do not expose the control box to direct extreme heat, cold or fluctuating temperatures
- Protect the control box against water entering and direct sunlight
- The power supply to the control box must have a lockable main switch next to the control box.
- Mount all necessary parts and fill every hole after installation
- Install emergency stop buttons at a level out of reach of the animals
- Install emergency stop buttons clearly visible and accessible
- Use approved cables and wires only; do not exceed the maximum cable length

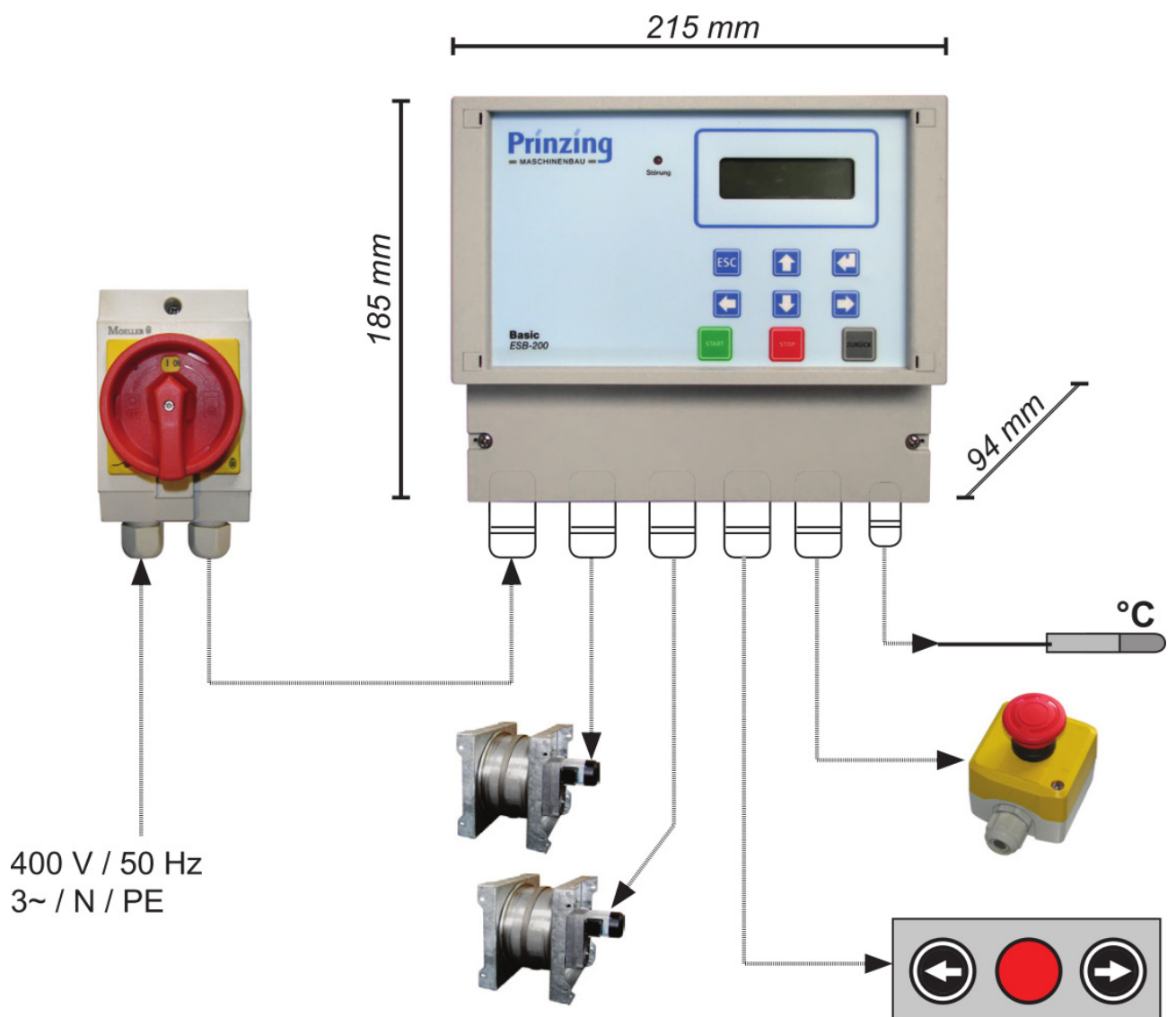

ESB-210

BASIC - Steuerung / BASIC-Controller

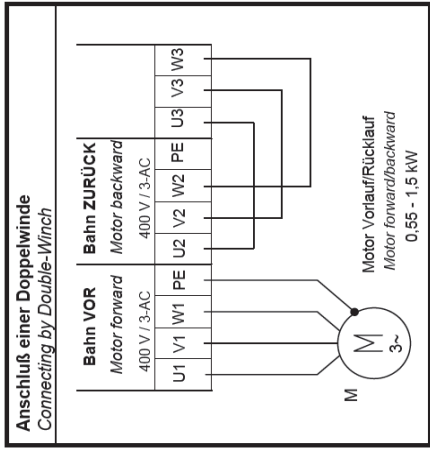
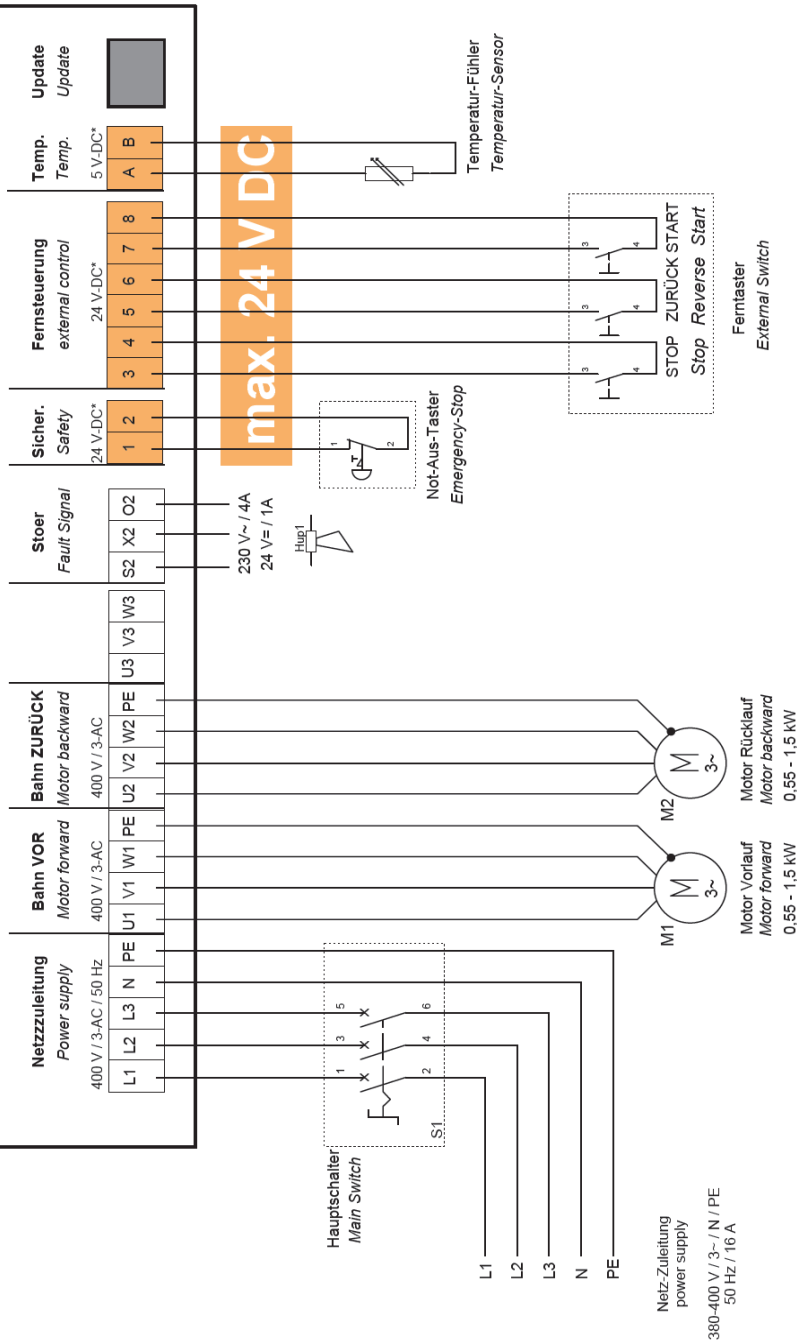
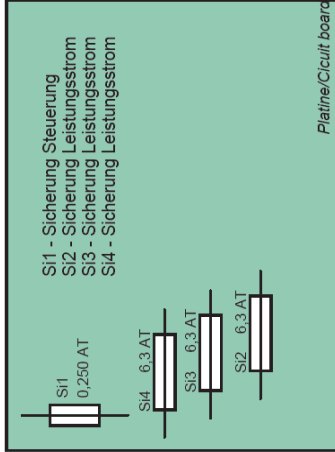

ACHTUNG!
In die Zuleitung der Steuerung muß ein Hauptschalter montiert werden!
CAUTION!
A main switch must be attached into the supply of the control!
* = erfordert bei Messung externen Schließer gegen Masse
= require external normally open contact at measuring against ground (mass)

Änderungen		Datum	Name	Bezeichnung	Blattzahl:
	Name	gez.:	LHE	Anschlussplan ESB-210	1
		gepr.:		Connecting plan ESB-210	Blatt-Nr.: 1/1
				Zeichnungs-Nr.:	esb-210_ap_v01

Prinzing
Peter Prinzing GmbH
Sicherheitslab 2
89173 Lomsbrunn-Untering
Tel.: 073 36 / 96 1000

4.6.4 Cable types, lengths and diameters

Device	Recommended wire type ¹	Min. wires	Voltage	Recommended max. length ²
Control box ESC 200 / ESB 210	NYM 5 x 1.5 mm ²	5	400 V / 3~ / 50 Hz	100 m
Extension module EXP 200	NYM 5 x 1.5 mm ²	5	400 V / 3~ / 50 Hz	
Drive motor 'forward' (Track 1...5) Drive motor 'backward' (Track 1...5)	NYM 5 x 1.5 mm ²	4	400 V / 3~ / 50 Hz	
Emergency stop ³	NYM 3 x 1.5 mm ²	2	24 V DC	100 m
External control buttons	NYM Cat 5 / Cat 7	6	24 V DC	100 m
Data cable extension module ⁴	LiYCY 2 (+1) x 0.25 mm ²	3	Use the pre-mounted EXP 200 cable only. Max. length = 1 m	
Temperature sensor	NYM 3 x 1.5 mm ²	2	5 V DC	10 m
Connecting blocks of the control box: WAGO with coloured marking, max. diameter 1.5 mm ²				

- ¹ Cable diameter to match the motor capacity and the cable lengths
- ² The cable length depends on the cable diameter and the load. Remember the low voltage cable (e.g. external control buttons) may cause faults in the control box through electromagnetic fields
- ³ Emergency stop
An emergency stop for every drive motor is recommended.
- ⁴ Data cable: older version LiYCY 4 x 0.25 ROHS, new design LiYCY 2 x 0.25 ROHS,
WARNING – check other colour codes of individual wires: (table below)

Identifier connecting block	Colour code old version LiYCY 4 x 0.25 ROHS	Colour code new version LiYCY 2 x 0.25 ROHS
G	Black	Black
D	Yellow	Brown
S	Green	White

Only authorised persons may work on the electrical connection of the control box and other electrical components. Satisfy yourself about the capacity and the voltage of the power supply before you connect any electrical components. The electrical connection of the control box and other electrical components are subject to current statutory regulations.

Required power supply: 400 V/3~/PE-N/50Hz. The connecting blocks for line voltage are located:

- In the integrated junction box of the COMFORT / BASIC control box
- In the extension module EXP 200



INFO
The appendices to these mounting instructions contain a wiring diagram for the control boxes

Diameter and colour code of the connecting blocks	
Diameter connecting blocks	Up to. 1.5 mm ²
Colour code connecting blocks	Grey >>> Line voltage 250 V~ Blue >>> Neutral Green >>> Earth Orange >>> Control voltage 5 – 24 V=

INFO



We assume no liability for damage as a result of the defective, unprofessional and/or not-prescribed electrical connection of the control box or electrical components. Neither will we accept warranty claims under such circumstances. The contracting installer is required to produce an inspection report in order to demonstrate that an authorised and certified person has correctly installed the electrical system. You are required to keep this report for future reference. Mutually linking two or more COMFORT control boxes is not allowed.

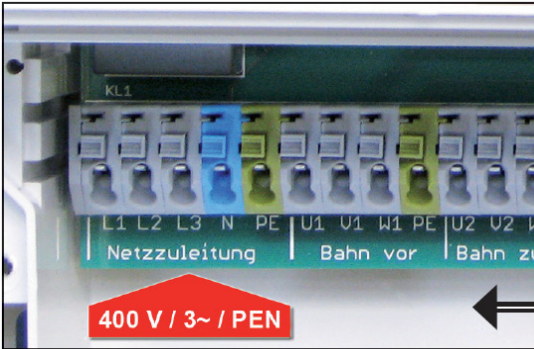

Line voltage connection ESC 200

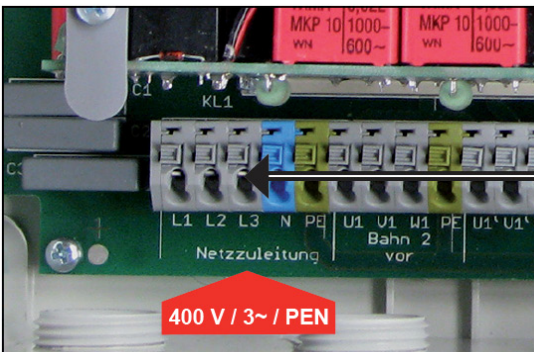

Line voltage connection EXP 200

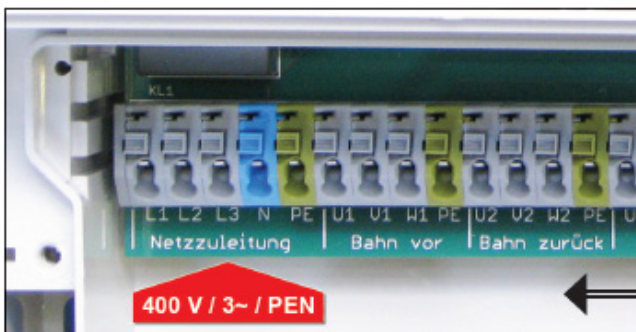

Line voltage connection ESB 210

4.7 Assembly of safety elements

Main switch (mounting externally)

The electrical connection of the manure removing equipment must be connected to a lockable main switch. The main switch;

- connects all parts of the installation to the power supply
- can be padlocked in the '0' position
- protects (by way of the padlock) against unauthorised persons switching the installation on

Emergency stop (mounting externally)

The installation must be connected to at least one emergency stop. Mount the emergency stop in a way that makes it easily recognisable and quickly to reach. Preferably at a location where a hazardous situation may arise, such as near a wall passage, a partition barrier or the drive motor.

We advise against the assembly next to the control box, since the main switch is also located next to the box.



PLEASE NOTE!

Do not bypass an emergency stop under any circumstances. Do not block access to the emergency stop. After activating the emergency stop, wiring in the control box will remain live!



PLEASE NOTE!

All emergency stops must be connected in series. Extra emergency stops are available from your dealer or from Spinder Stalinrichting.

Operating the emergency stop:

Press the emergency stop in the event of a hazardous situation. The installation will stop immediately and numbers on the display will start blinking. When the danger has passed: pull the emergency stop and push the START button to resume the programme that was interrupted by the emergency stop.

Extra safety measures

Extra safety measures can be taken to make the installation even safer:

- separation barrier near a wall passage
- safety switch strip near a wall passage
- hook-up wire along the entire channel



PLEASE NOTE!

All extra safety measures must be connected in series to the existing emergency stop

Protective covers

Before the installation is put into operation, make sure that all protective covers that came with the equipment are duly assembled. For separation barriers, please contact Spinder Stalinrichting.



PLEASE NOTE!

Do not disassemble or disable the protective covers while the installation is in use.

4.8 Motor test (testing the direction of rotation of the motor)

The motor test is to determine the direction of rotation and must be carried out:

- After installing new drive units.
- After repairing or replacing a drive unit.
- After connecting or repairs to the motor or the connecting blocks.
- Before changing the motor's direction of rotation: change the phase in the control box.



INFO

To test the direction of rotation, press the 'ZURUCK' (backward) or the 'VOR' (forward) key on the control box.



PLEASE NOTE!

Change the phase in the control box before you change the motor's direction of rotation.

4.9 Attaching the rope



PLEASE NOTE!

Check that the installation is entirely installed before you attach the rope. The check should include all safety components (emergency stop, safety fences, etc.). Make sure that no people are within the working range of the scraper installation.

4.9.1 Attaching the rope to the installation

Follow the steps below to attach the rope to the installation (see chapters 4.9.2 and 4.9.3 for mounting the rope to the drive unit and scraper):

- 1) Determine the rest position of the scrapers, from here it is "motor forward".
- 2) Lean the manure scrapers against the corner wheels.
- 3) Wind the rope five times around the drive unit (motor forward) (see chapter 4.9.2).
- 4) Attach the rope to the drive unit.
- 5) Pull the rope tight around the drive unit.
- 6) Run the rope around the corner wheel (the first wheel from the drive unit) and below the stop to the manure scraper. **Put the protective cover on the corner wheel.**
- 7) Attach the rope to the front of the manure scraper (lift socket) (see chapter 4.9.3).
- 8) Attach a second piece of rope to the back of the manure scraper.
- 9) Run the rope around the corner wheels to the back of the manure scraper, second manure scraper. **Put the protective covers on the corner wheels.**
- 10) Attach the rope to the back of the second manure scraper.
- 11) Make sure that channels are free from any obstacles.
- 12) Push the "start" button on the control box only once.

WARNING: the manure scrapers will now start moving until they come to rest against the stop!

- 13) Wind a third rope five times around the drive unit (motor backward).
- 14) Attach the rope to the drive unit.
- 15) Pull the rope tight around the drive unit.
- 16) Run the third rope around the corner wheel and below the stop to the second manure scraper. **Put the protective cover on the corner wheel.**
- 17) Attach the rope to the front of the manure scraper (lift socket).
- 18) Make sure that channels are free from any obstacles.
- 19) Push the "zurück" button on the control box only once.

WARNING: the manure scrapers will now start moving until they come to rest against the stop!

- 20) Move the system back and forth a few times, using the "start" and "zurück" buttons on the control box.
- 21) Adjust the length of the second rope so that both manure scrapers reach their maximum stroke. Remember the elasticity of the rope (3 - 4%).



PLEASE NOTE!

If the installation has only one channel, put the manure scraper into the starting position and follow steps 1 - 7 and 10 - 15 for installing the rope. Coming to step 16, attach the rope to the back of the manure scraper. Then proceed with steps 18 - 20.

installation of rope in system

- 1) Determine the rest position of the scrapers, from here it is "motor forward". In this diagram "motor forward" is at the bottom.
- 2) place scraper A against corner pulley D
- 3) place scraper K against stop J
- 4) Wind rope five times around drive drum E (motor forward)
- 5) Attach the rope to drive drum E Pull the rope tight around drive drum E
- 7) run the rope around corner pulley C and below stop B to manure scraper A
- 8) place the protective cover on the corner pulley C
- 9) Attach the rope to the front of manure scraper A
- 10) Attach a second piece of rope to the back of manure scraper A
- 11) run the rope around corner pulleys D and H to the rear of manure scraper K
- 12) place the protective covers on the corner pulleys D and H
- 13) Attach the rope to the rear of manure scraper K
- 14) Make sure that channels are free from any obstacles
- 15) Push the "Start" button on control box F only once

WARNING: the manure scrapers will now start moving until scraper A comes to rest against stop B!

- 16) Wind a third rope five times around drive drum G (motor backward)
- 17) Attach the rope to the drive drum G
- 18) Pull the rope tight around drive drum G run the third rope around corner pulley I and below stop J to manure scraper K
- 20) place the protective cover on the corner pulley I
- 21) Attach the rope to the front of manure scraper K
- 22) Make sure that channels are free from any obstacles
- 23) Push the "zurück" on control box F only once

WARNING: the manure scrapers will now start moving until scraper K comes to rest against stop J!

- 24) Move the system back and forth a few times, using the "start" and "zurück" buttons on control box F
- 25) Adjust the length of the second rope so that both manure scrapers reach their maximum stroke
- 26) place the protective covers on the corner pulleys E and G

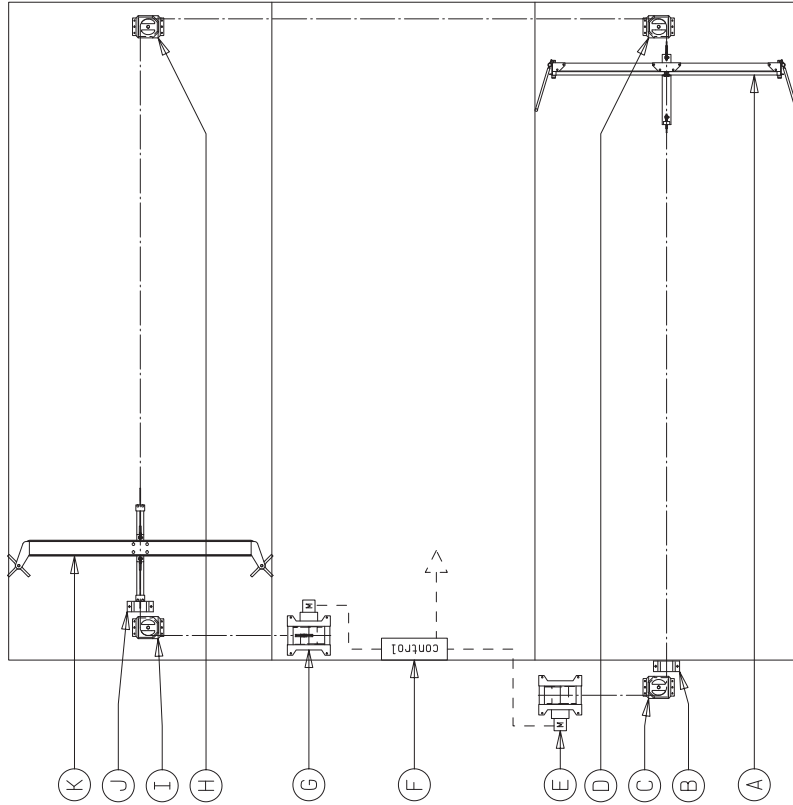

installation of rope in system

Nr.:	170-016	Blad nr:	1:1
Schaal:	1:50	Maateenh:	mm
Ger.nr.:	0000	A3	
Datum:	30-10-2014	Get.:	P.d.J. J. J.
		Ger.:	

Tekening blijft ons eigendom en mag niet gereproduceerd, aan derden getoond of op andere wijze worden gebruikt.



installation of rope in system

- 1) Determine the rest position of the scrapers, from here it is "motor forward". In this diagram "motor forward" is at the left.
- 2) place scraper A against stop F
- 3) Wind rope five times around drive drum D (motor forward)
- 4) Attach the rope to drive drum D
- 5) Pull the rope tight around drive drum D
- 6) run the rope around corner pulley C and below stop B to manure scraper A
- 7) place the protective cover on the corner pulley C
- 8) Attach the rope to the front of manure scraper A
- 9) Make sure that channels are free from any obstacles
- 10) Push the "Start" button on control box E only once

WARNING: the manure scraper will now start moving until scraper A comes to rest against stop B!

- 11) Wind a second rope five times around drive drum G (motor backward)
- 12) Attach the rope to the drive drum
- 13) Pull the rope tight around drive drum G
- 14) run the rope around corner pulley and below stop F to manure scraper A
- 15) Attach the rope to the rear of manure scraper A
- 16) Make sure that channels are free from any obstacles
- 17) Push the "zurück" on control box F only once

WARNING: the manure scraper will now start moving until scraper A comes to rest against stop F!

- 18) Move the system back and forth a few times, using the "start" and "zurück" buttons on control box E
- 19) place the protective covers on the corner pulleys E and G

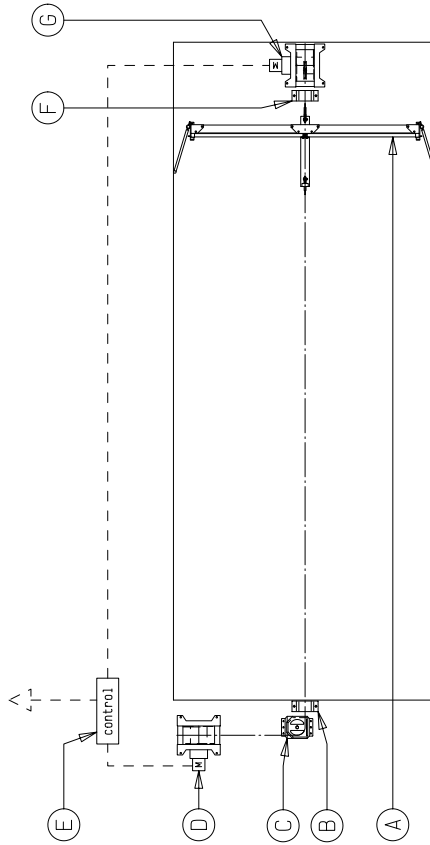

installation of rope in system

Nr.:	170-019	Blad nr:	1:1
Schaal:	1:50	Maateenh:	mm
Ger.nr.:	0000	A3	
Datum:	30-10-2014	Get.:	P.d.J.
		Ger.:	

Tekening blijft ons eigendom en mag niet gepubliceerd, aan derden getoond of op andere wijze worden gebruikt.



4.9.2 Attaching the rope to the drive unit

Tie a knot at the end of the rope. The knot (sufficiently big but not too big for the slot in the drum) must be hooked into the hole of the drum. Subsequently, wind the rope 5 or 6 times around the drum. Wind the rope evenly across the width of the drum; do the same with the second and subsequent layers. Always wind the rope in the direction of pulling of the drum (see illustration).

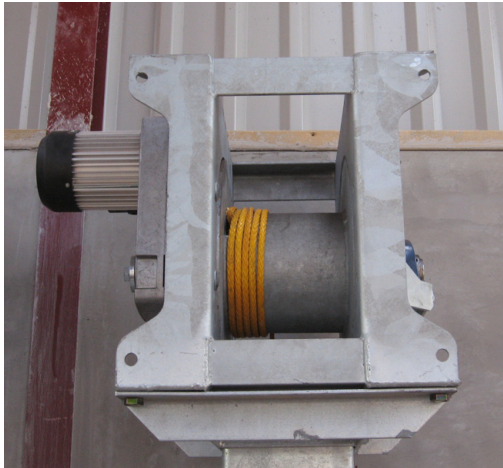

Winding the rope onto the drive unit

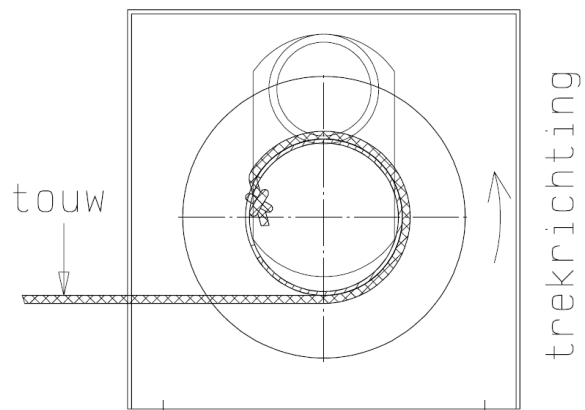

Attaching the rope to the drive unit



INFO

The elasticity of the rope is 3 - 4%. As a result, the rope between the manure scrapers may have to be shortened after several runs.

4.9.3 Attaching the rope to the scraper

Using a lift socket, the rope is attached to the scraper.

- The rope first runs through the curve on the guide strip (for scrapers with guides only).
- The rope runs subsequently through the (small) bottom hole of the lift socket (to the inside).
- The rope then folds around the wedge and back through the same bottom hole (to the outside).
- By firmly pulling the rope, the wedge will clamp the rope into the lift socket.
- A knot will secure the rope (or by way of two cam locks).
- After the rope is secured in the lift socket, remove the bolt (M12), attach the lift socket and refit the bolt (M12).

These mounting instructions contain a drawing that shows the attachment of the rope to the scraper.



The elasticity of the rope is 3 - 4%. As a result, the rope between the manure scrapers may have to be shortened after several runs.

Disassembly of lift socket

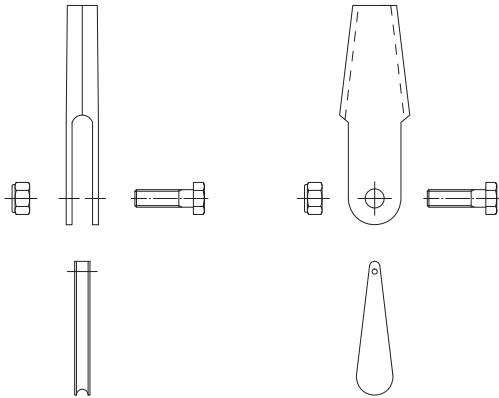

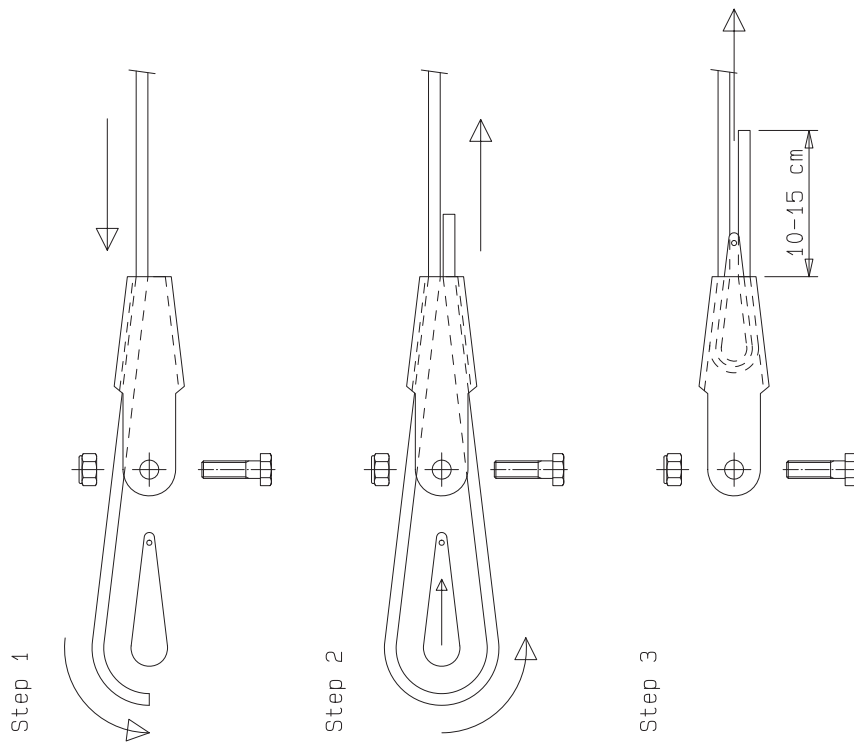

Mount rope in lift socket and pull

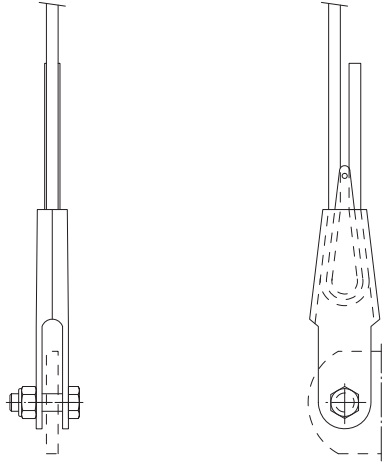

Assembly of lift socket



Assembly of lift socket

Nr.:	170-017	Blad nr.:	1:1	 stalinrichting Harkema-Holland	Tekening blijft ons eigendom en mag niet gereproduceerd, aan derden getoond of op andere wijze worden gebruikt.
Schaal:	1:3	Maateenh:	mm		
Ger.nr.:	0000	 A3			
Datum:	30-10-2014	Get.:	P.d.J.		

4.10 Adjusting the brake band

After correctly fitting the brake band, the drive unit will run more roughly unwinding (direction of pulling) than winding. The rope inlet may come from the other side. In that case, turn the brake band around. Also in this instance, the unit should run more smoothly than in the case of winding the cable (see illustration –brake band fitting).

The tension spring of the brake band to the drive unit should make the unit stop if the motor is turned off or in the case of switching from forward to backward. That is to prevent the rope from winding loosely around the drum, causing knots or tangles. Tighten the brake band if the tension is insufficient (by tightening the nut on the spring).



The spring of the brake band should always point into the direction of pulling.

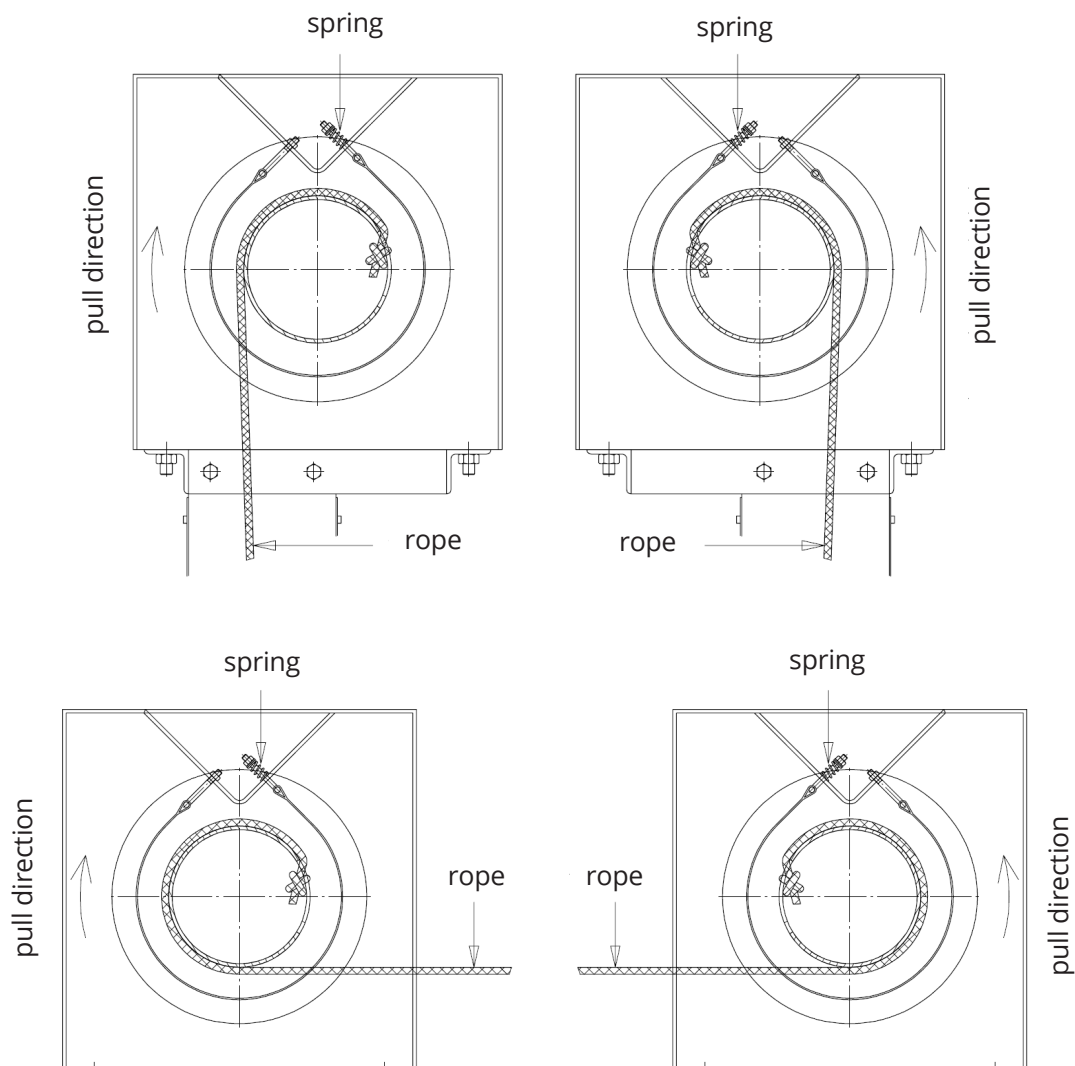

Dry or moist air may cause squeaking. In that case, lubricate the brake band using (WD 40) oil.

5 Maintenance

After maintenance



- All tools, materials and other objects must be taken away and put somewhere outside the working range of the scraper installation.
- Check that all safety components have been fitted.
Check the emergency stop / motor safety switch after turning the main switch on.
- Do a test run on the scraper; be aware of any strange noises and error messages.

5.1 Drive unit

While the drive motor is running, check for leakage, oil level and noises. Prevent blockage of the air grate of the motor. A blocked air grate may cause overheating of the motor.

5.2 Corner pulleys

When inspecting the corner wheels, also check the disc function, the pin for cleaning the disc and the condition of the protective cover.

Clean the disc if necessary; also check the bearing bush for wear and tear. Replace any damaged discs. Check that the fastening bolt is firmly in place.

5.3 Manure scraper

Check that the rope is correctly attached to the manure scraper, that the valves / stars are free from wear, and check for any deficiencies or damage.



INFO

For safety reasons, have the installation inspected every year.

5.4 Maintenance summary

Parts of the installation	Check	Maintenance frequency / type of maintenance
Corner wheels	runner wheel / bearing bush	2 weeks following the start-up of the installation; then once a month
Safety precautions	In place	2 weeks following the start-up of the installation; then once a month
Gear box (motor drive)	Oil level	Oil change after running 1,000 hours
Bearing unit	Vertical bearing	Every 12 months; check for sufficient lubrication.
Scraper	Rope attachment Cable clamps	2 weeks following the start-up of the installation; then every second month. Check the cable clamps for correct attachment.
Rope	Wear	Check the rope for damage every third month.
Control box	Disconnect from power mains	After putting into operation; continually thereafter. The scraper should not run too fast towards the safety precautions – increased wear on rope! Check the time and temperature settings.
	Function	Locking the covers and compression couplings.

5.5 Gearbox – type of oil and quantity

Drive motor – model	Recommended type of oil	Quantity
ABM – 0,55 kW – HM 333	ARAL – DEGOL BG 220	1,2 Litres
ABM – 0,75 kW – FGA 1353	ARAL – DEGOL BG 220	2,8 Litres
Lenze – 0,9 Kw – GFL 07-..	ARAL – Eural Gear 220	4,3/4,6 Litres (depending on the mounting position)

* Recommended type of oil is transmission oil

6 Technical data

These technical data are for model:	Scraper installation rope drive
Model no.:	See model plate on the control box
Year of manufacture:	2012
Drive motor capacity in KW	0.55, 0.75, 0.9 and 1.1
Diameter corner wheel	200 mm
Model manure scraper	Slat scraper, combi scraper straight and combi scraper V-shape
Diameter rope	8 and 10 mm
Max. tensile load of the rope, depending on the model - in kg:	6000 kg – 9000 kg

Electric installation values ESC 200:

Supply voltage: 400 V / 3~ / 50 Hz, neutral conductor, earth connection:	400 V / 3~ / 50 Hz, neutral conductor, earth connection
Supply voltage to neutral conductor:	minimum: 205 V~ • normal: 230 V~ • maximum: 250 V~
Power consumption in standby mode:	approx. 5 Watt
Switching output motor:	max. 3.5 A/phase
No. of drive units / motors:	1 / 2
Fault message output, maximum load:	potential-free, 4 A at 250 V~ • 1A at 24 V=
Output transversal transport, maximum load:	potential-free, 4 A at 250 V~ • 1A at 24 V=
Cross section cable terminals:	max. 1.5 mm ²
Safety class:	IP 54
Ambient temperature	-20.....50 °C
Air humidity:	max: 75 %
Colours of the terminals	Grey >>> supply voltage 250 V~ Blue >>> neutral conductor Green >>> earth connection Orange >>> control voltage 5 - 24 V=

Electric installation values ESB 210:

Supply voltage: 400 V / 3~ / 50 Hz, neutral conductor, earth connection:	400 V / 3~ / 50 Hz, neutral conductor, earth connection
Supply voltage to neutral conductor:	minimum: 205 V~ • normal: 230 V~ • maximum: 250 V~
Power consumption in standby mode:	approx. 5 Watt
Switching output motor:	max. 3.5 A/phase
Fault message output, maximum load:	potential-free, 4 A at 250 V~ • 1A at 24 V=
Output transversal transport, maximum load:	potential-free, 4 A at 250 V~ • 1A at 24 V=
Cross section cable terminals:	max. 1.5 mm ²
Safety class:	IP 54
Ambient temperature	-20.....50 °C
Air humidity:	max: 75 %
Colours of the terminals:	Grey >>> supply voltage 250 V~ Blue >>> neutral conductor Green >>> earth connection Orange >>> control voltage 5 - 24 V=

Electric installation values EXP 200:

Supply voltage: 400 V / 3~ / 50 Hz, neutral conductor, earth connection:	400 V / 3~ / 50 Hz, neutral conductor, earth connection
Supply voltage to neutral conductor:	minimum: 205 V~ • normal: 230 V~ • maximum: 250 V~
Power consumption in standby mode:	approx. 5 Watt
Switching output motor:	max. 3.5 A/phase
No. of drive units / motors	2 / 4 (each EXP 200)
Length data cable:	Max. 1 metre (Use the pre-mounted cable only)
Cross section cable terminals:	max. 1.5 mm ²
Safety class:	IP 54
Ambient temperature	-20.....50 °C
Air humidity:	max: 75 %
Colours of the terminals:	Grey >>> supply voltage 250 V~ Blue >>> neutral conductor Green >>> earth connection Orange >>> control voltage 5 - 24 V=

EC declaration of conformity

(according to directive 06/42/EC, appendix II, sub A)

Spinder Dairy Housing Concepts
Zeppelinlaan 3
9207 JG Drachten

Phone: 00 31 512 237 800
Fax: 00 31 512 364 244
Internet: www.spinder.nl

hereby declares that:

the manure processing installations, models:

- 65.12.100
- 65.12.105
- 65.12.150
- 65.12.155

Fitted with scrapers for slatted floors and/or closed floors, in the condition as the installation is supplied,

are in compliance with the relevant and essential provisions of the Machine Directive (directive 06/42/EC);

comply with the relevant and essential provisions from the following other EC directives:

- EMC directive (04/108/EC)

and further declares that relevant elements of the following European (harmonised) standards have been applied:

- NEN- EN IEC 61000-6-3
- NEN- EN 55011
- NEN- EN ISO 12100
- NEN- EN 61000-6-4
- NEN-EN IEC 60204-1
- NEN- EN 61000-6-2
- NEN- EN ISO 13857

Authorised person for putting together the Technical Construction Dossier

R&D staff member
Street address
Postal code and City

Done at, Harkema
Date: 13 – 7 - 2012

On behalf of Spinder Stalinrichting BV ,

Name:

Signature: